

World War I Trainer - K-Boat

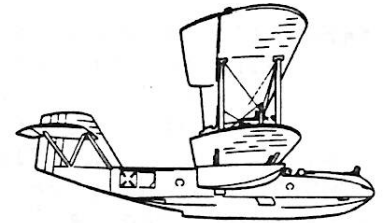

MAXECUTERS



First All-metal PN-8 - 1921



Liberty Powered F5-L

MAX - FAX

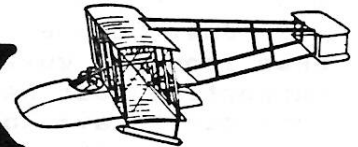

Curtiss "Owl" - 1913

THE NEWSLETTER OF THE D.C. MAXECUTERS

JULY/AUGUST 1987

MEMBERSHIP

Dues for membership in the D.C. Maxecuters is \$10.00 per year for residents of the U.S.A., Canada, and Mexico, and \$11.00 for all other countries. Your mailing label indicates the year and month of the last issue of MAX-FAX for your current membership. A red mark next to your mailing label is a reminder that your current membership is nearing its end. Send a check, payable to D.C. Maxecuters, to the Treasurer.

MEETINGS

The D.C. Maxecuters hold meetings on the first Wednesday of every month at the College Park Airport, the oldest continuously operating airport in the world.

PRESIDENT

BILL CERESA
11410 Blueridge Drive
Beltsville, MD 20705

SECRETARY

BERT PHILLIPS
1709 Crofton Parkway
Crofton, MD 21114

TREASURER AND NEWSLETTER EDITOR

ALLAN SCHANZLE
20008 Spur Hill Drive
Gaithersburg, MD 20879

***** NOTICE *****
THE "DREADED RED X" NO LONGER APPEARS ON THIS PAGE. IT NOW APPEARS NEXT TO YOUR MAILING LABEL ON THE OUTSIDE COVER. THE INCREASED VOLUME OF SUBSCRIBERS, AND HENCE "RENEW-EE'S", DICTATES THIS CHANGE TO BE NECESSARY.

UPCOMING EVENTS

- July 19 1987: Old Timer Rubber Contest at COMSAT.
- Aug 9 1987: FAC Power Contest at COMSAT. Note new date. Any power.
- Sept 12 1987: MAXECUTERS SUMMER FUN FLY at COMSAT. See Flyer this issue.
- Sept 26 1987: FAC Contest at Fayetteville, North Carolina.
- Oct 3 1987: Lindbergh/Trans-Atlantic Commemorative at COMSAT.

CLUB NEWS

ALLAN SCHANZLE

The following letter was received from Pat Daily. I think it expresses the feelings of all local MAXECUTERS, namely camaraderie.

"In the midst of all the turmoil in the Daily household right now, I thought I would take a minute or two to drop you a note. I want to thank you and all the D. C. MAXECUTERS from the bottom of my heart for the great

farewell cookout at your place this past Sunday evening. Tell Connie the best part was the strudle - next to the wurst and beer, of course.

"I realized, while I was sitting on your patio sucking on my third Coors, that the time to leave was approaching at warp factor 7. I will really miss the flying sessions in the late evening summer sunshine at COMSAT and the great indoor flying during the winter. But most of all, I'll miss you and all the guys more than I can express. I figure I can fly anywhere there is the room, and I can build anywhere - but it won't be the same without the fantastic camaraderie of the local group of MAXECUTERS. My hope is that the Navy will send me back to D. C. after the Philippine tour. I wish I could count on it.

Just 'cause I'm out of sight for a while doesn't mean I don't want to hear from you guys. Please keep in touch. If nothing else, think of it as supporting your NAVY! I really will miss you guys a lot. Did you know that they don't have Roy Rogers in Subic? What a shame!

Once again, thanks for the party and the past 15 years of good friendship - I'll never forget. Pass this note along to the gang. If I'm lucky, I may see you guys at the next FAC NATS. Every time I look at the picture of the Fokker (Ed. A going away gift to Pat from the local gang) I'll wish you the best of thermals. Pat".

That just about says it all, as far as your editor is concerned. To you, Pat, best wishes from us all. You can reach him through the following address.

Capt O. P. Daily
U. S. Navy Hospital
Box 26 FPO
San Francisco CA 96652-1600

A few other items of Club news should also be mentioned, compliments of the sharp eye of Tom Schmitt, who found that the Editor did some "non-editing". The last issue of MAX-FAX had some errors (translate that into "typo's"). First of all, the Flyer for this summer's FUN FLY had "FAC CO-2 Scale" listed. This should have been "FAC POWER Scale". (Open to CO-2, Gas, and Electric). Next, the Trans- Atlantic Crossing event is open to ANY type of power, not just rubber. And, I really screwed things up by giving a Monday date for the North Carolina Contest. The correct date is September 26, two weeks after our local bash. Finally, we may decide to eliminate the qualifying flight for the Summer FUN FLY. The problem is that there are four scale events, and the work of the judges may be overwhelming. HOWEVER, you can bet your sweet bippy that you will not see your static score unless you make a qualifying flight. And, your score will not be included in the published results. So there!!!!

One other note, thanks also to Tom Schmitt. (Why isn't HE Editor, if he finds all these errors?) By close review of the real photo of the LA 11 presented in the last issue, Tom noted that the landing gear should most likely be black, not light gray, as noted on the plans. I agree with this conclusion, but I still question Tom's other observation that the struts should also be black. My feeling is that they should be gray. When I judge, I'll accept either, unless Tom builds the thing, in which case he will automatically be wrong, regardless of the color of his struts!!!!

A note arrived at ye 'ole editor's desk from Bob and Sandy Peck. They have two new kits available. A Bostonian, called the "PUP", and the FLYING ACES "MOTH". Quite a few of us locals have built the Moth, and that sucker really flies great. Others have had difficulty with this model, but those of us here who have powered it for long gradual flights, as opposed to high powered climbs, have found it to be a real ozone seeker. A coupon for \$1.00 discount appears to the right. Make a copy of it (good Gawd, you wouldn't really cut up this newsletter, would you?) and send it with your order. I don't have a Bostonian for this

\$1.00 DISCOUNT
"PUP" + "MOTH"

Send this coupon to
Peck-Polymers - Get
\$1.00 off each kit
Moth for \$7.95 ,Pup
for \$6.95 + \$2.00
post. Good till
Sept. 30,1987

winter's flying, so you can bet I'll build this one in the next few months.

Good grief!!! I almost forgot to mention the FAC contest sponsored by Dave Smith, down in South Carolina. As I recall, six of us from the Maryland area went down to this bash, and had a great time. Dave had a party at his house thnight before. I think he put something in the drinks, in an attempt to snocker us for the next days activities. But it wasn't to be. Our G-2 department discovered this dastardly southern deed and swapped beers. "Twas old Dave who was snake bit the next day. Or was it just good 'ole fashioned southern hospitality on his part? Whatever, it was a great time and we all thank Dave for his efforts in this contest.

A notice came from Bill Hannan, announcing ANOTHER book, PEANUTS AND PISTACHIOS Vol 2. Check elsewhere in this issue for the details and contents.

Finally, a note came from Bob Longseth (5906 Wakefield Dr., Sylvania, Ohio, 43560 -- For cryin' out loud, Bob, is your street really "Wakefield" Dr.? What some guys won't do to promote this hobby.) It seems that some of his model mags got damaged by water, and he is looking for replacements. The specific issues are as follows: MODEL AIRPLANE NEWS, 1984, Feb. and April, 1986, Nov. and Dec., MODEL BUILDER, 1985, Nov., 1986, Jan. and July. If you can help him out with replacements, drop him a note.

This issue features a plan for our Atlantic Crossing event this fall. It's another one of those obscure aircraft that Hurst Bowers seems to find amidst the clutter of the AMA Library (just kidding Hurst, you've got that library in great shape, as can be testified to by anyone who has taken the time to visit the facility.) The 3-view included in this issue leaves much to be desired, since the original was in color, and black and white copies of color paintings just don't hack it. More details can be found about this aircraft in the book ATLANTIC WINGS, by Kenneth M'cDonough. Some construction hints from our compatriots at PAX River, a few contest results, a really swell drawing by Otto Kuhni, another embryo plan by Dick Howard, a 3-view of the Potez 43 (a WHAT?, I hear you cry), and photo pages by Tom Schmitt round out this issue. Hope you enjoy it.

2 NEW! Peanuts & Pistachios 2

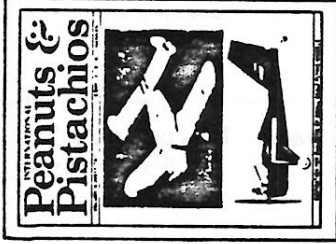

INSPIRATION FOR BUILDERS

You asked for more! So here is the second volume of PEANUTS & PISTACHIOS. Compiled by Bill Hannan, this concise booklet of truly international scope, displays the work of modelers, photographers and artists from many parts of this world, including: Czechoslovakia, England, France, Germany, Japan, Switzerland, Uruguay, and various of the United States of America.

PEANUTS & PISTACHIOS features articles, 3-Views & plans, handy-hints, suggestions and encouragement for builders of small scale flying models. These miniatures offer FUN in much larger proportions than their miniscule size may lead you to think. Why not share in the pleasures of these low-cost, high-performance model aircraft?



Small can be satisfying!

HIGHLIGHTS OF THIS BOOKLET!

- Advantages (and negative advantages!) of PEANUTS & PISTACHIOS
- Feedback from Volume One readers (extracts from letters)
- Pistachio Pointers - Peanuts & Pistachio Pointers
- Peanuts & Pistachios Photography in a Nutshell (Say cheese!)
- The Peanut Gallery & The Pistachio Presentation (photographs)
- Peanuts & Pistachios Producers (who build these things, anyhow?)
- 3-view drawings by Emanuel Fillen (France), Harry Robinson (England), Jim Alaback (California) and Bill Hannan (Ditto)
- SUBJECTS: 1911 Caudron monoplane w/vec 3 cylinders motor
1928 Mignet Avionette parasol monoplane
1936 Mauboussin Hemipiere tandem
1985 TEAR miniMAX Proof-Of-Concept ultralight
Ken Johnson (California)
Ken Johnson (California)
- SUBJECTS: 1948 Bebe Jodel low-winger
1921 Waterman Goaling racer parasol

FORMAT: 8 1/2" x 11" size, two-color glossy 10 pt. card-stock cover; 16 80-lb.-stock pages, 32 photos, 6 line drawings plus sketches and cartoons. NO ADVERTISING. ISBN 0-961652-4-3

VERY LIMITED PRINTING... DON'T MISS OUT... ORDER YOURS TODAY!
\$4.95 plus postage and handling of \$1.50. NOTE: Two copies of PEANUTS & PISTACHIOS can travel at the same postage rate as one copy in the U.S. or by foreign surface rate. Why not order an extra copy for a friend? Autographed if desired!



PHOTO PAGES

Tom Schmitt

1. A great plane for the Lindberg/Trans-Atlantic Commemorative; this issue's plan the 'OISEAU CANARI' by Hurst Bowers.
2. The local Maxecuter gang at Pat Daily's going away party; 'host with the mostest' Allan Schanzle on lower right!

COLUMBIA S.C. FUN FLY

3. Pat winding 'TOOTS' for a winning last fling at FAC contest flying for a couple of years.
4. Claude Powell with his great flying new ZERO, test flown just the day before the contest.
5. Dave Platt came from Florida with a fleet of free flight models including this terrific unlimited.
6. Dave Rees winding his SKYRAIDER for the MODERN MILITARY Mass Launch.
7. Dave Smith our gracious host in S.C. won the above event with his high flying F-84.
8. Bruce Rippeteau holds up his nifty catapult launched A7.
9. His son Luke had a Guillow TYPHOON ready to go.
10. Jason Webb shown here with his Keith Rider JACKRABBIT which was a major contender among the raceplanes.
11. FAC newcomer Tom Savage with a REARWIN SPEEDSTER in GOLDEN AGE.
12. Paul Gaertner journeyed from Georgia to fly this magnificent Fiesler with Bill Brown assisting.
13. An ill-fated SKYRAIDER by Don Srull in the MODERN MILITARY.
14. Col James Duckworth the Eastern Division rep for American Junior demonstrated the 'INTERCEPTOR' which is once again available.
15. Genial Bob Wedell left his new Mazda RX-7 long enough to fly an Earl Stahl MIG in the WWII event.
16. Another entry in the RACEPLANE event was this TIME FLIES BY Bill Gibbs.

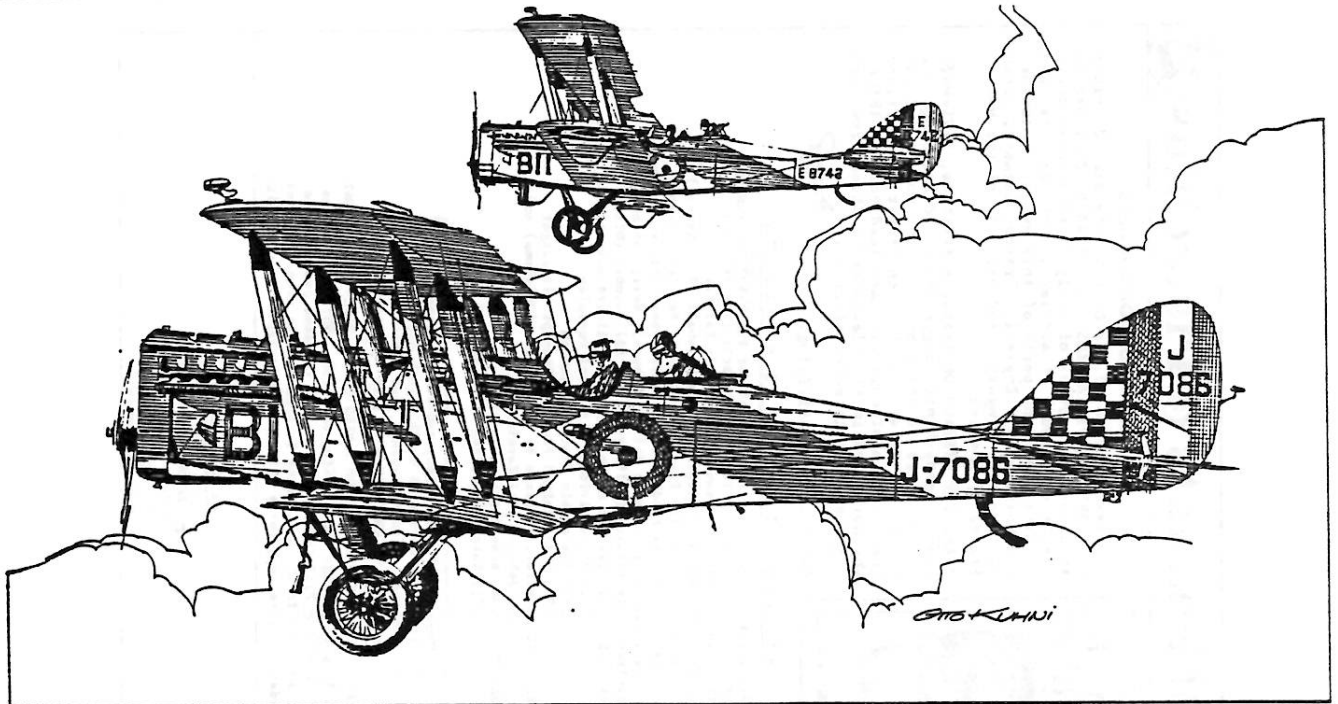

DH-9A "NINAKS" of B Flight 47 Squadron, Helwan, Egypt. Pilot of J-7086 is Fl. Lt. S.D. MacDonald; his pet "Monty" is in back with gunner.



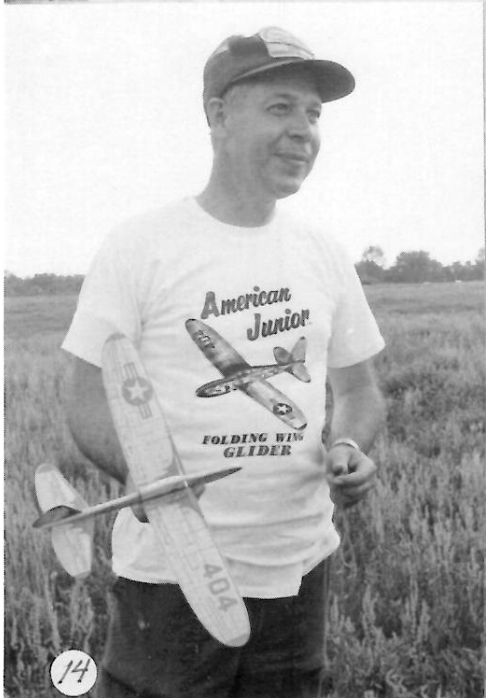

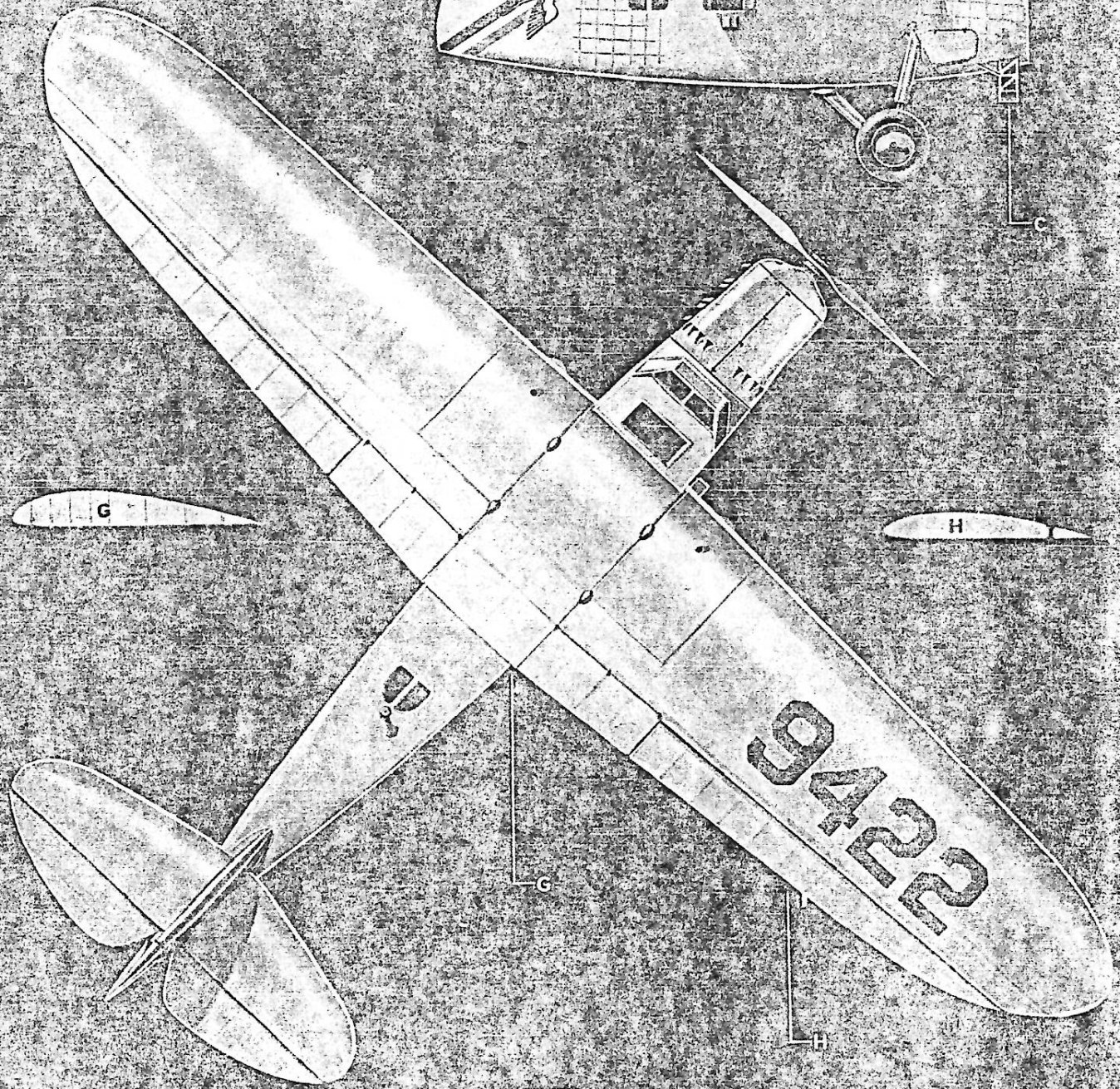
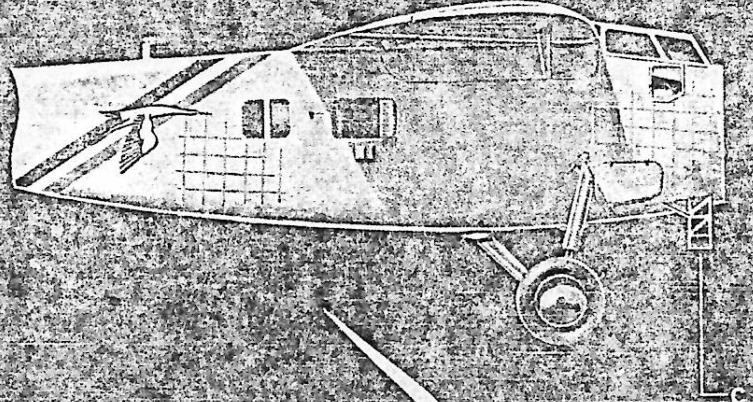
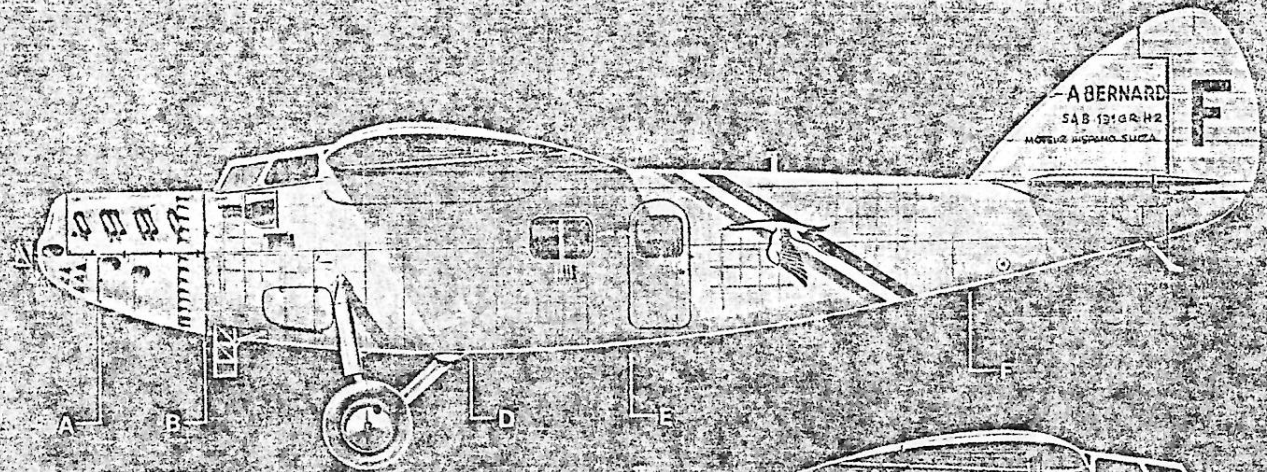

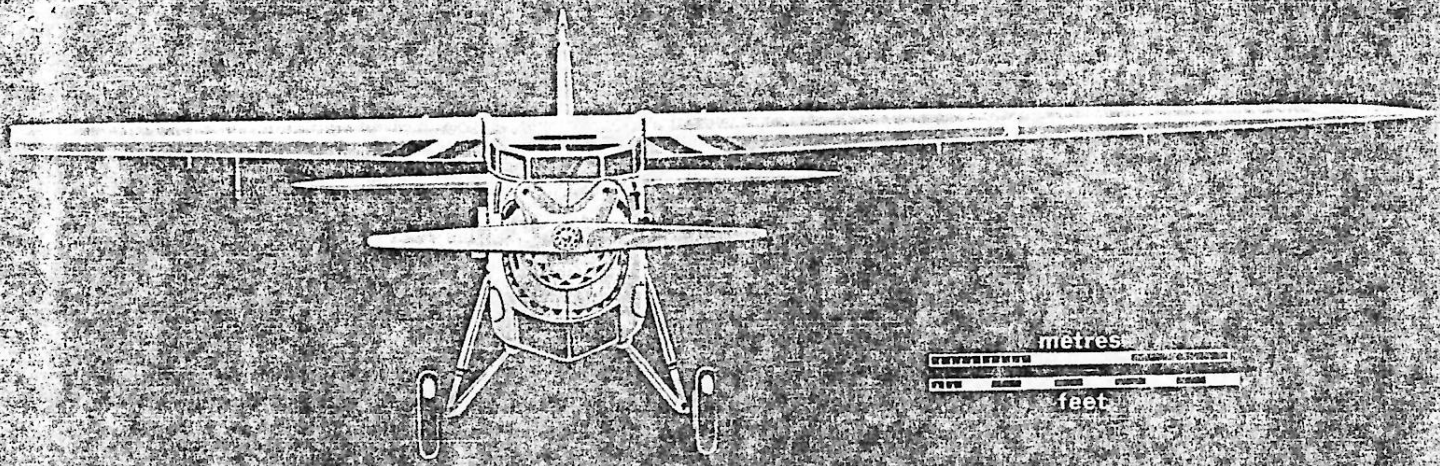

metres
feet

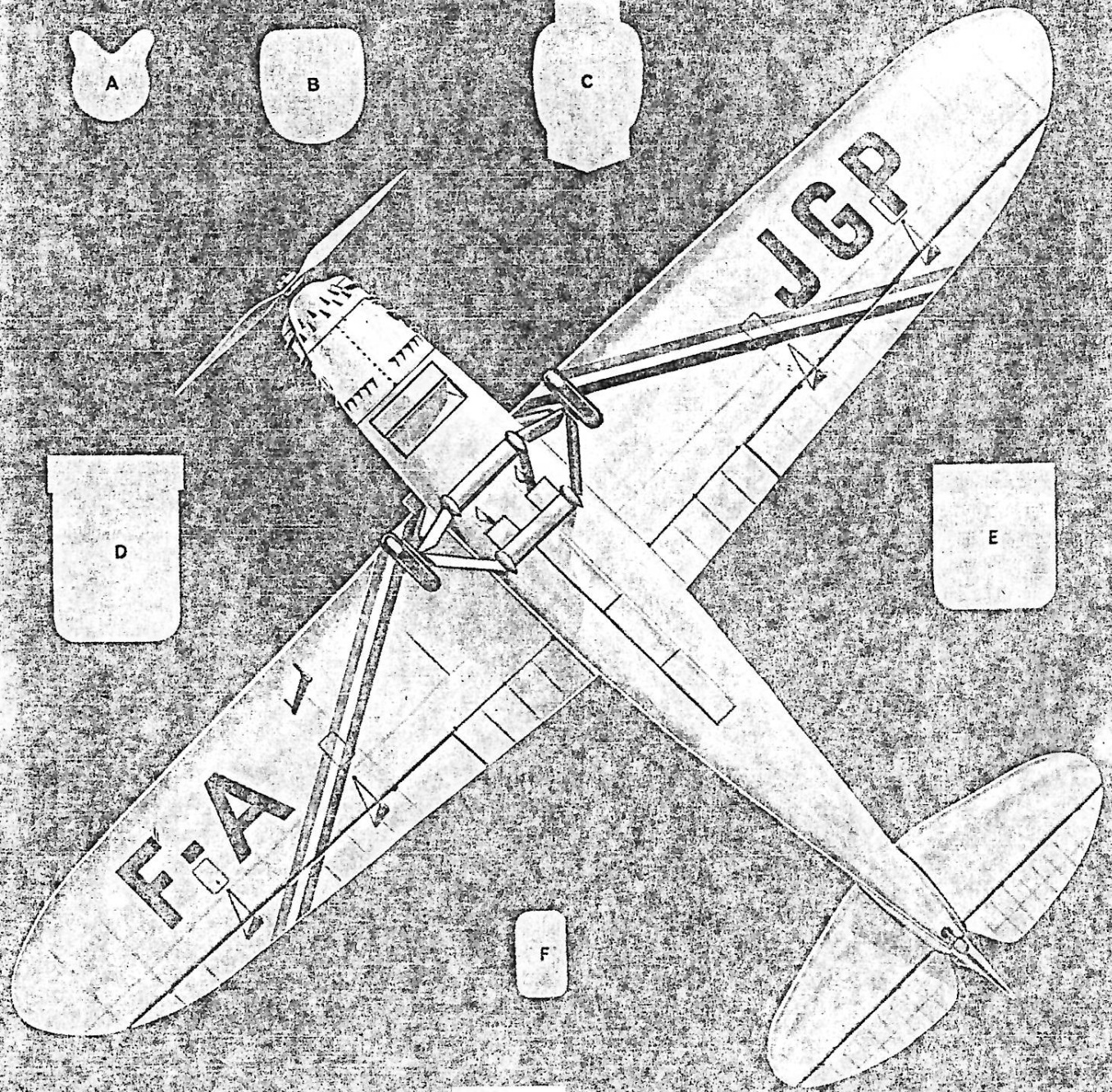
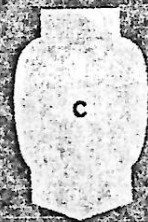
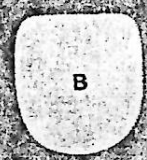

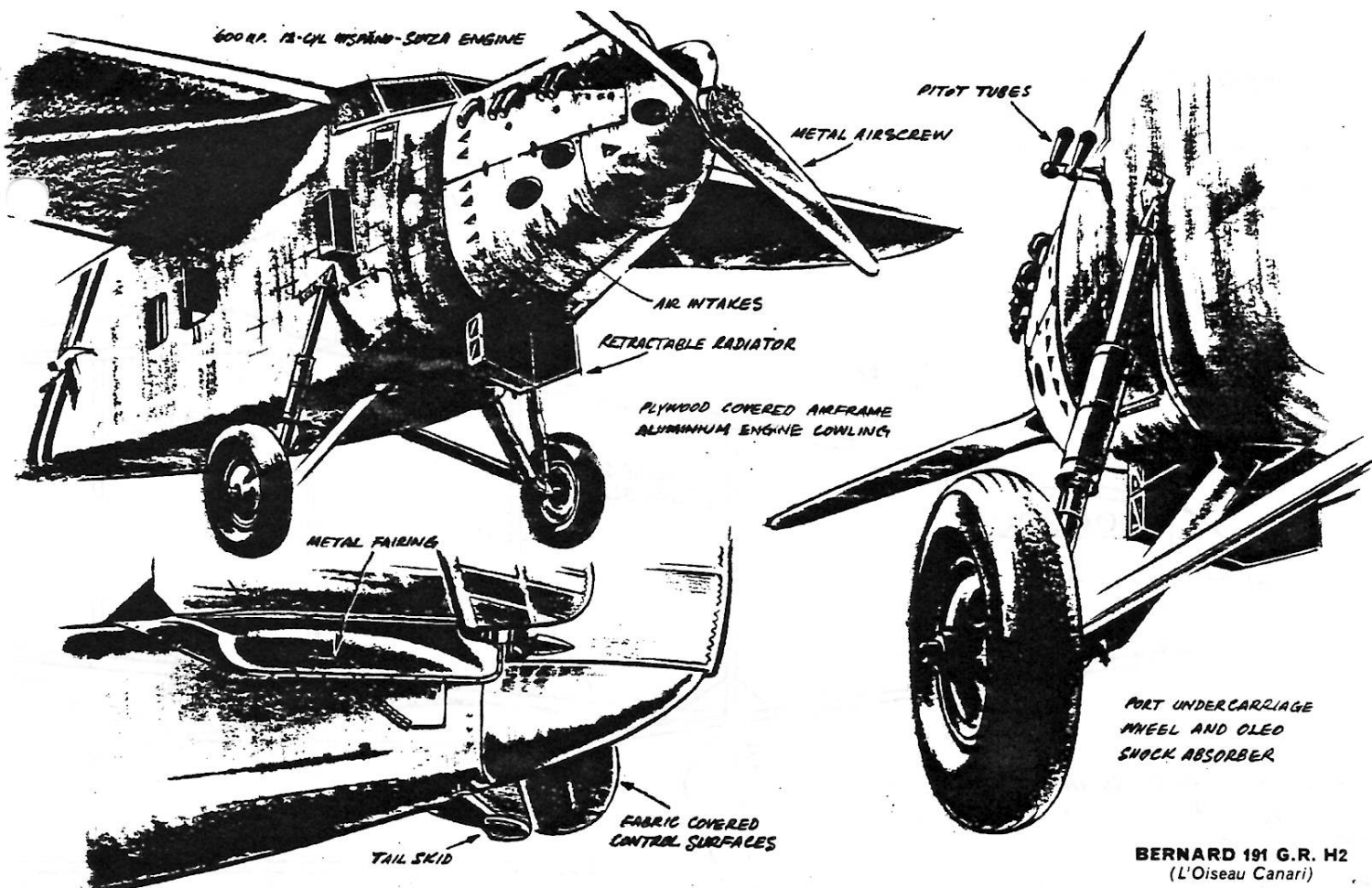

BERNARD 191 G.R. H2
(L'Oiseau Canari)

WW I MASS LAUNCH COMSAT 31 MAY 1987

CONTESTANT	AIRCRAFT	ROUND ELIMINATED					PLACE
		1	2	3	4	5	
DAN DRISCOLL	SES	X					
BRUCE PRICE	SE6						1
CLAUDE POWELL	DHS				X		2
ALLAN SCHANZLE	SUNKER DE			X			3
JERRY FRISLEY	ALBATROS VIII		X				

WW II MASS LAUNCH COMSAT 31 MAY 1987

CONTESTANT	AIRCRAFT	ROUND ELIMINATED					PLACE
		1	2	3	4	5	
BERT PHILLIPS	SPITFIRE II		X				
BRUCE PRICE	HELLCAT			X			3
BILL CERESA	P-51	X					
CLAUDE POWELL	ZERO		X				
DOUG BUCHANAN	NIKITIN		X				
ALLAN SCHANZLE	HELLCAT						1
TOM SCHMITT	WILDCAT				X		2

WW I / WW II FLYOFF DUEL COMSAT 31 MAY 1987

CONTESTANT	AIRCRAFT	WINNER
ALLAN SCHANZLE	HELLCAT (WWII)	
BRUCE PRICE	SES (WWI)	✓

EMBRYO BIPE
"COLD TURKEY"

DICK HOWARD

WING MOUNT PEGS (BAMBOO)

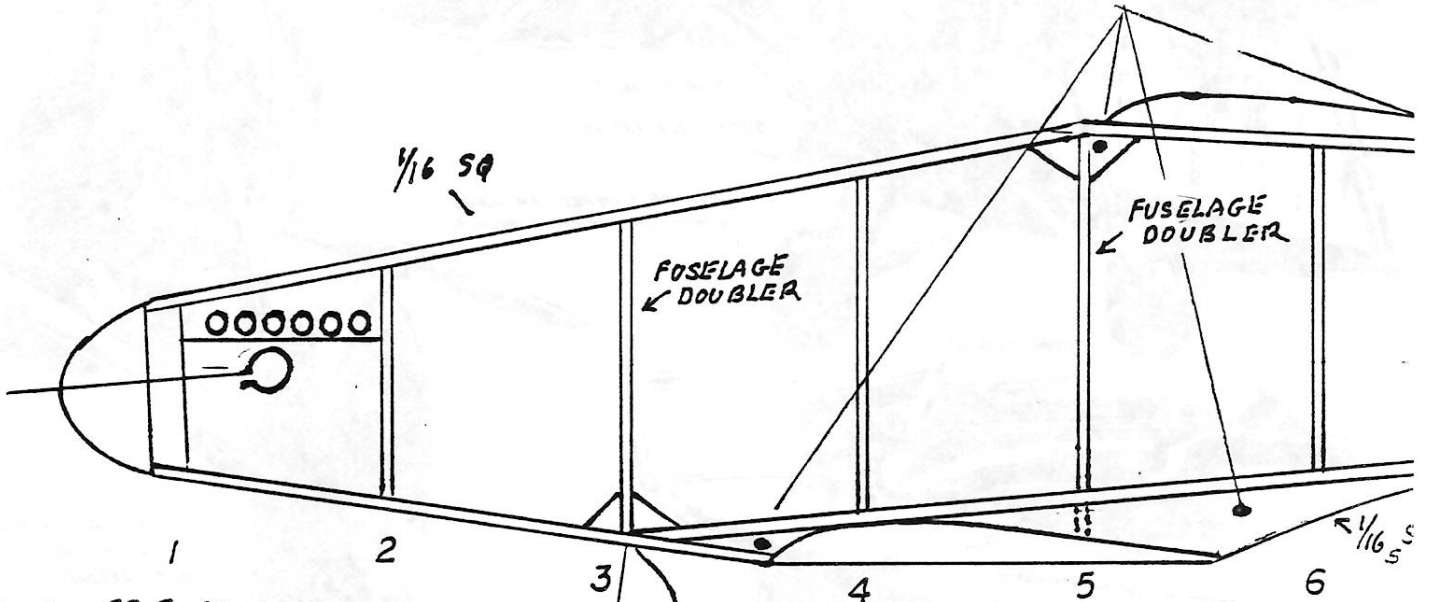

TOP WING 39.5 SQ IN
 B. WING 30.5 " "
 TOTAL AREA 70 " "
 DIHEDRAL B. WING 1/2"
 " T WING 5/8"
 PROP 7" DIAM
 MOTOR 2 LOOPS 3/32 P.A.-1. 24"

TYP. RIB SECTION

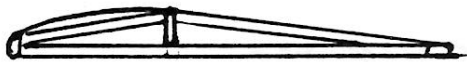

1/16 x 1/8
↓

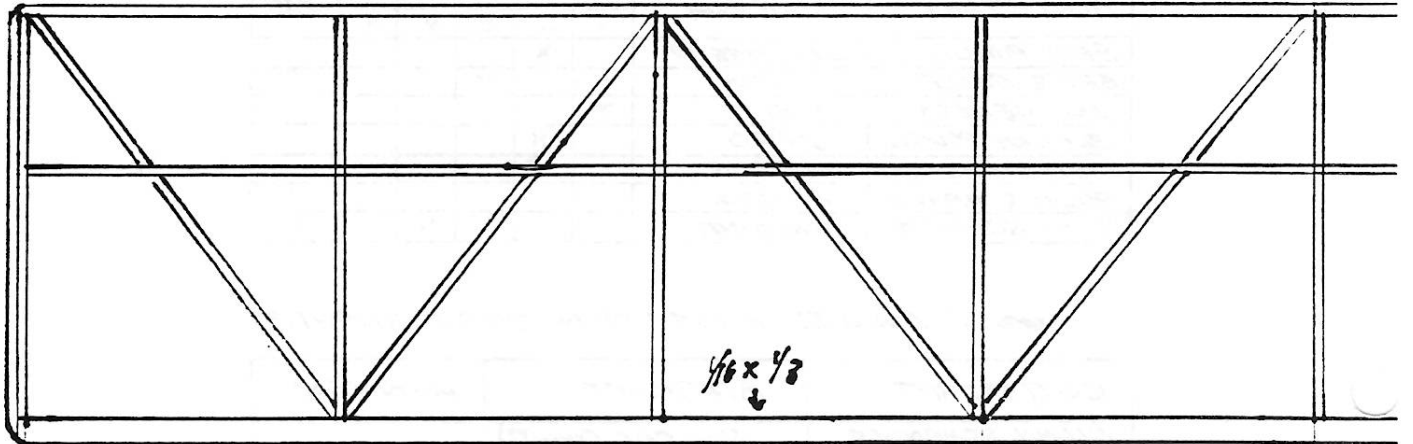
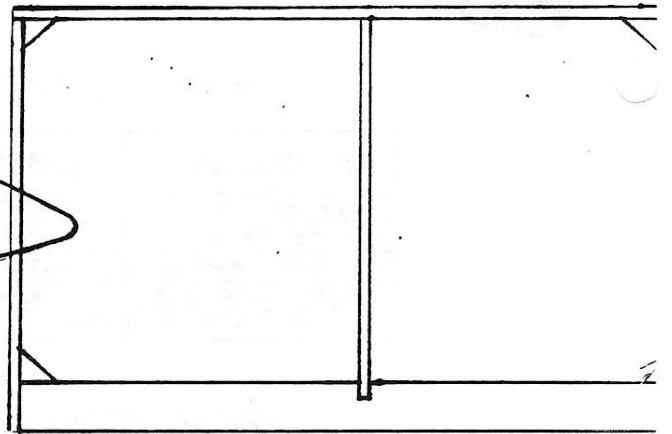

10. ————— BOTTOM WING

CONSTRUCTION HINTS
From around the country

From Tony Peters: In the past I have been plagued with crushed in wing leading edges, particularly indoors where my models insist on rushing headlong into table legs and basketball backboards. This fall I started gluing a length of Kevlar thread to the leading edge. Since Kevlar doesn't stretch, it should spread the impact along the length of the wing and keep the point of impact intact with negligible weight and no cosmetic penalty. I glue it on with the same wood glue that I use on the structure. So far this indoor season, I haven't pushed in a single leading edge despite my usual calamitous wall banging. Of course, I haven't banged in any of my other, unprotected models either...perhaps the Kevlar works like a protective charm or amulet and its protection covers all my models.

From John Walker: Since I fly, when I can, in an area that plays heck with the leading edges of the wings of my models, I found that with just a small increase in weight I can have "armor plate" leading edges. I have been substituting small diameter aluminum tubing for the wood. It hasn't been too much of a handicap because in two out of three cases we must add weight to the nose anyway. Curved leadings are also a cinch.

D.C. MAXECUTER'S '87 SUMMER

FUN FLY

Sept 12

AMA SANCTION 882

CONTEST DIRECTOR
ALLAN SCHANZLE
20008 SPUR HILL DR.
GAITHERSBURG MD. 20879
(301) 840-5884



900
to
500

EVENTS

FAC SCALE:

Judging starts at 11:30 AM. Qualifying flight must be made by this time.

MILITARY GOLDEN AGE: An event for these aircraft that are entered in FAC SCALE.

FAC JUMBO SCALE:

Qualifying flight by 11:30 AM.

FAC POWER SCALE:

Qualifying flight by 11:30 AM. FAC Power rules.

MASS LAUNCH:

The Races 1:00 PM. A single launch for all racers.
WW I 2:00 PM. A 5 second bonus for multi-wings.
WW II 3:00 PM. Only aircraft designed for combat.
Golden Age 4:00 PM. Any aircraft built from 1920 to 1935 and any plane not designed for military use from 1935 to 1940. Planes eligible for the races excluded.

Trans-Atlantic

Crossing 5:00 PM. To be held only if at least 3 models are entered. Open to all modes of power.

EMBRYO:

FAC rules.

H.L. Glider:

AMA rules

CATAPULT GLIDER:

Must use MAXECUTER launching pole. AMA H.L. rules.

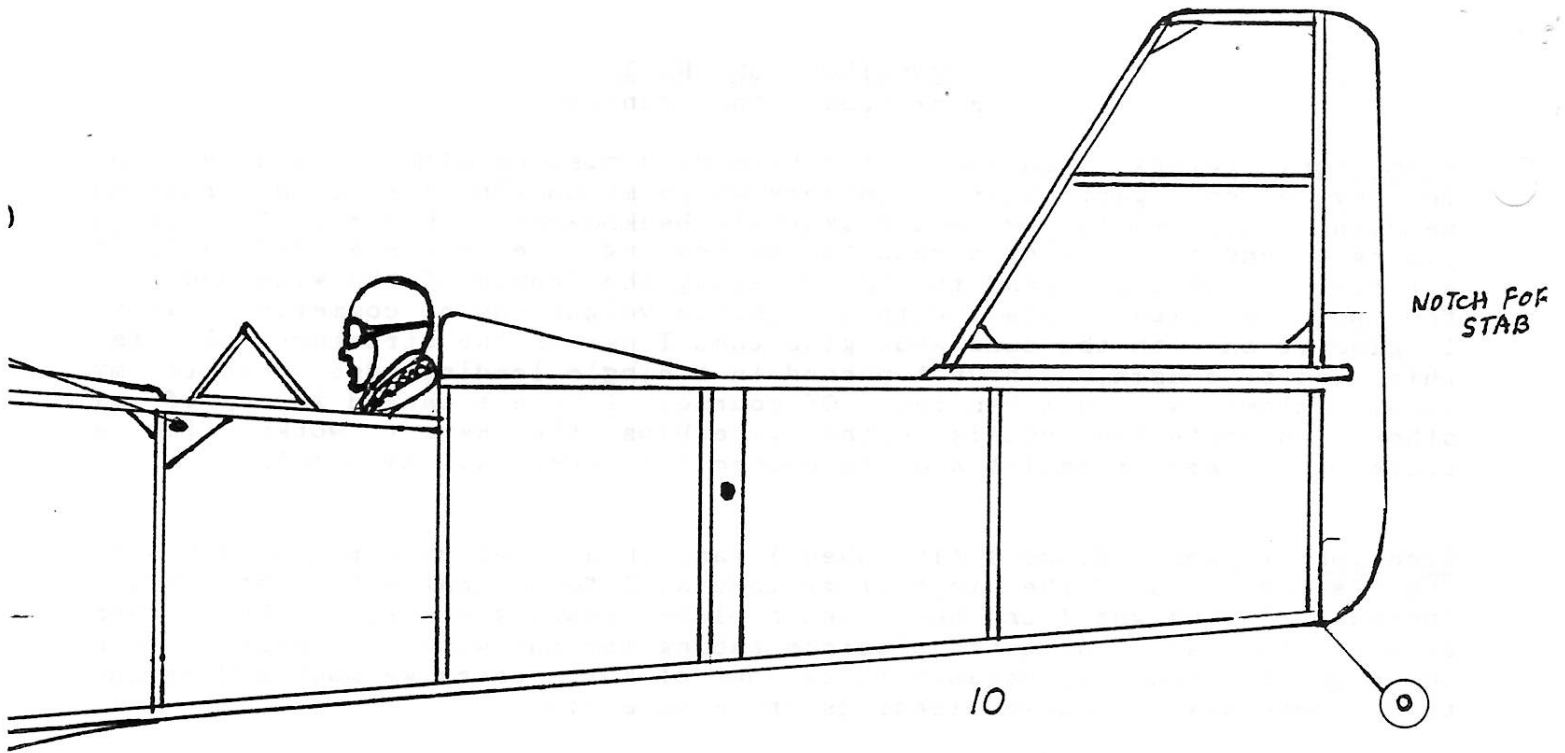

SHEET

7

8

9

FUSELAGE CROSS PIECE WIDTH
1-2-4-6-7-8

FUSELAGE DOUBLERS
BUILD OVER PLAN

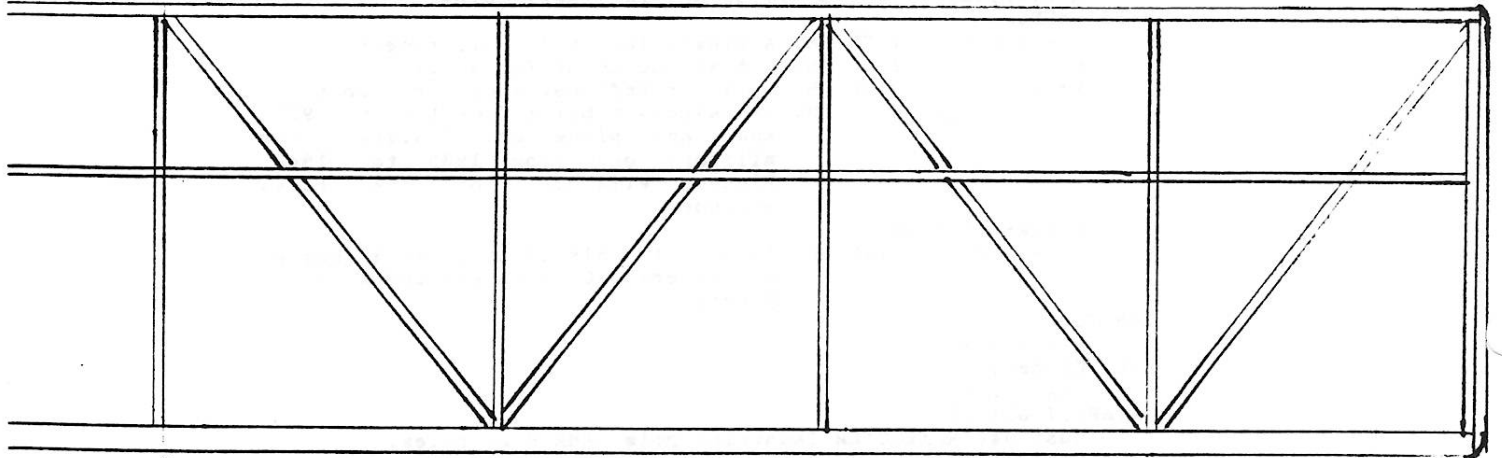
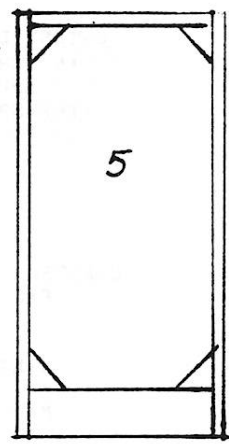
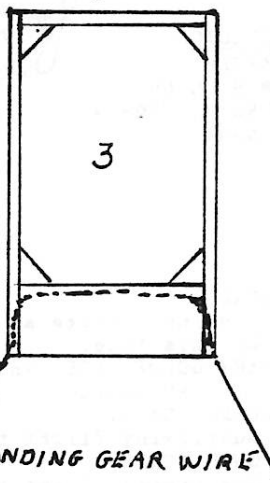
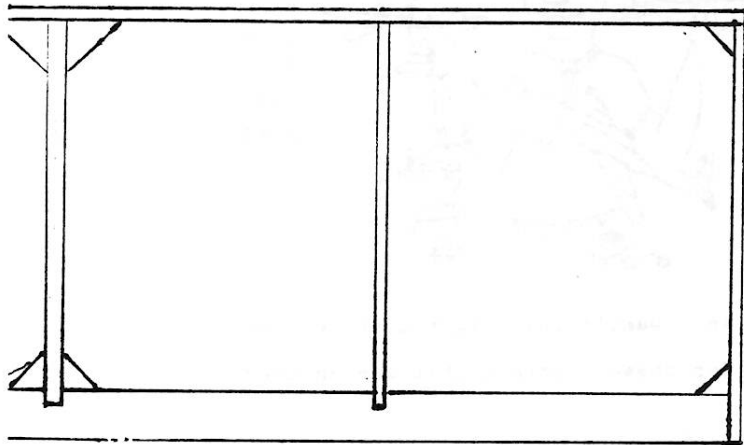

DIHEDRAL BREAK

12

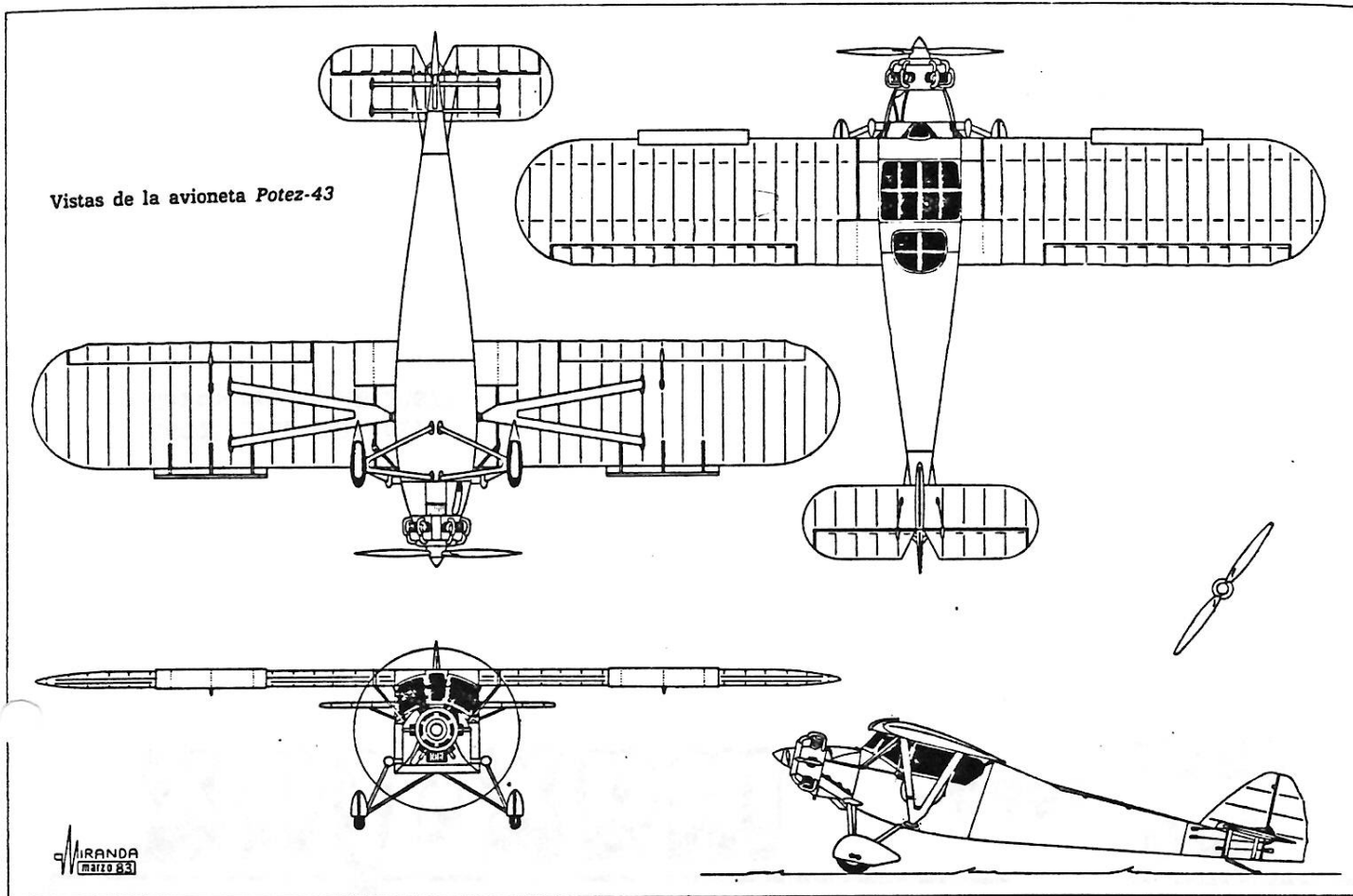

MORE CONSTRUCTION HINTS

From Claude Powell: Rounding edges of struts, wing leading edges, etc.

1. Sand at angle to edge.
2. Wipe edge with sandpaper to complete rounding.

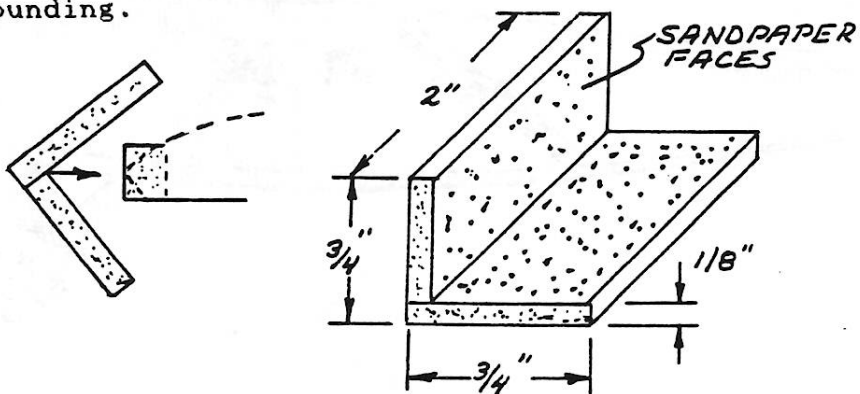

DUES DUE

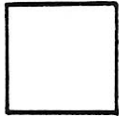

FIRST CLASS

2008 Spur Hill Dr.
Cathetersburg MD 20879

JULY
AUG 1987

max-fax

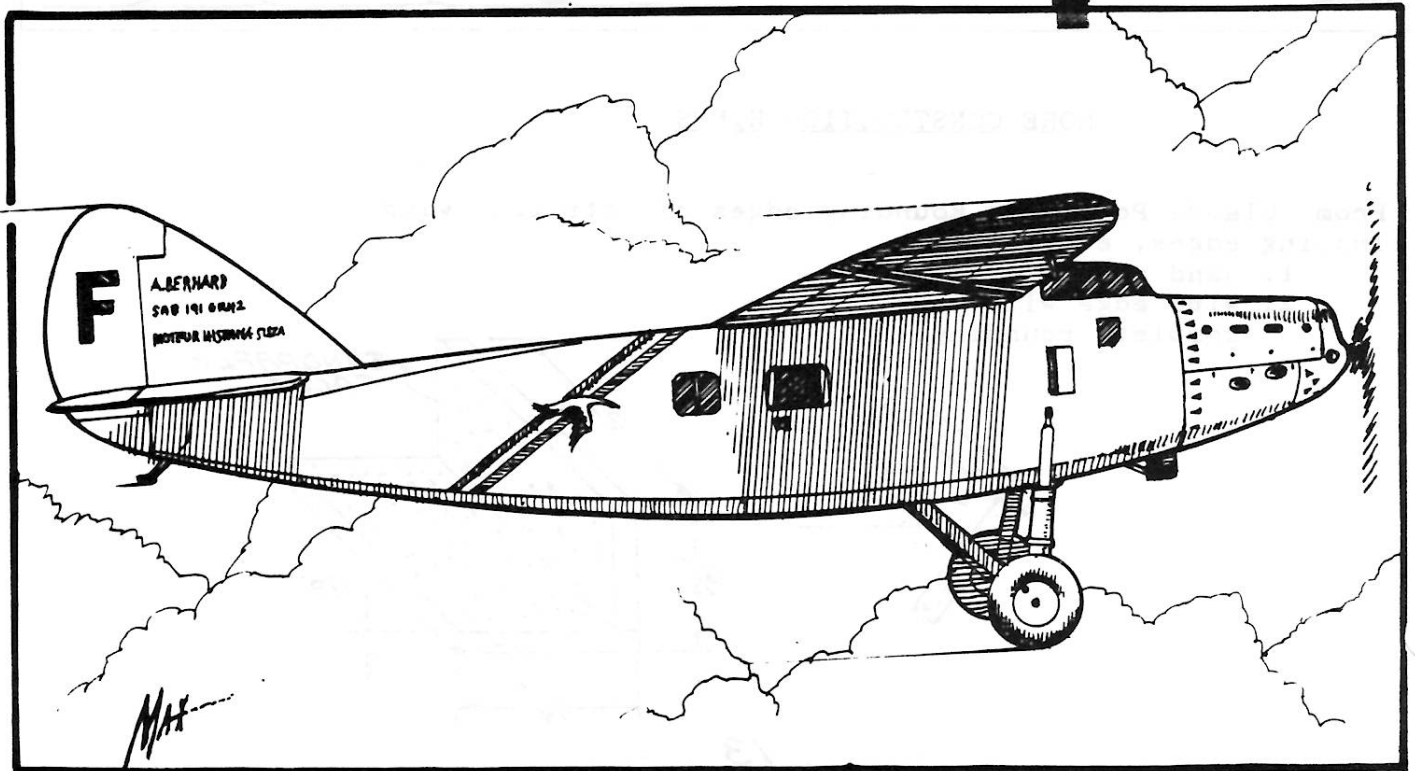

NUMERAL "9422" ON TOP OF RIGHT WING ONLY.
 COLOR IS BLACK AND PRESUMED TO BE U.S.
 REGISTRATION NUMBER

LETTERS " F-A JGP " ARE BLACK AND IS
 FRENCH REGISTRATION BOTTOM OF WING ONLY,
 OUTBOARD OF CHEVRONS

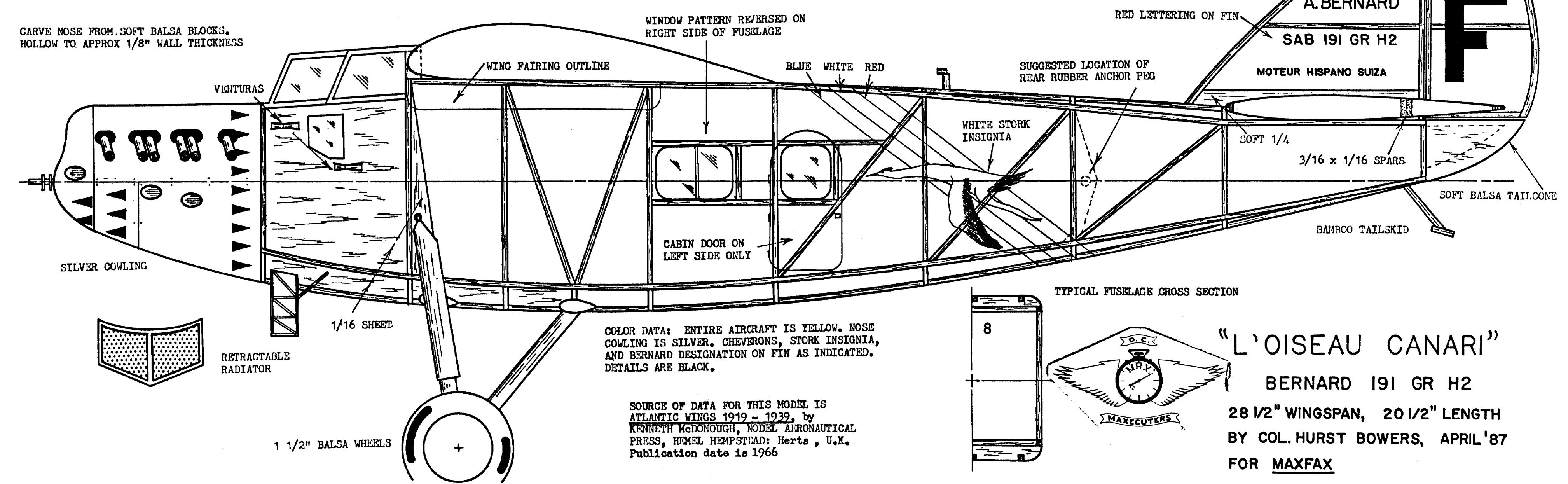
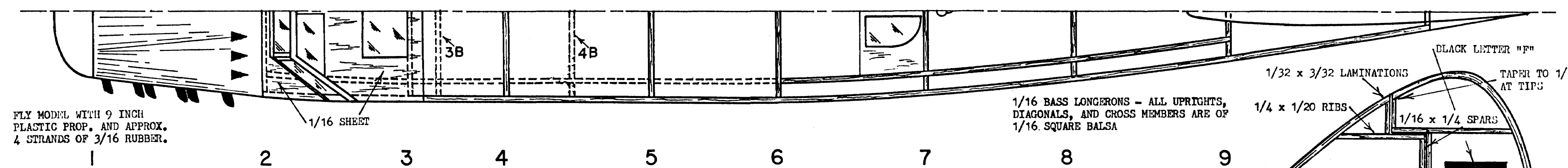
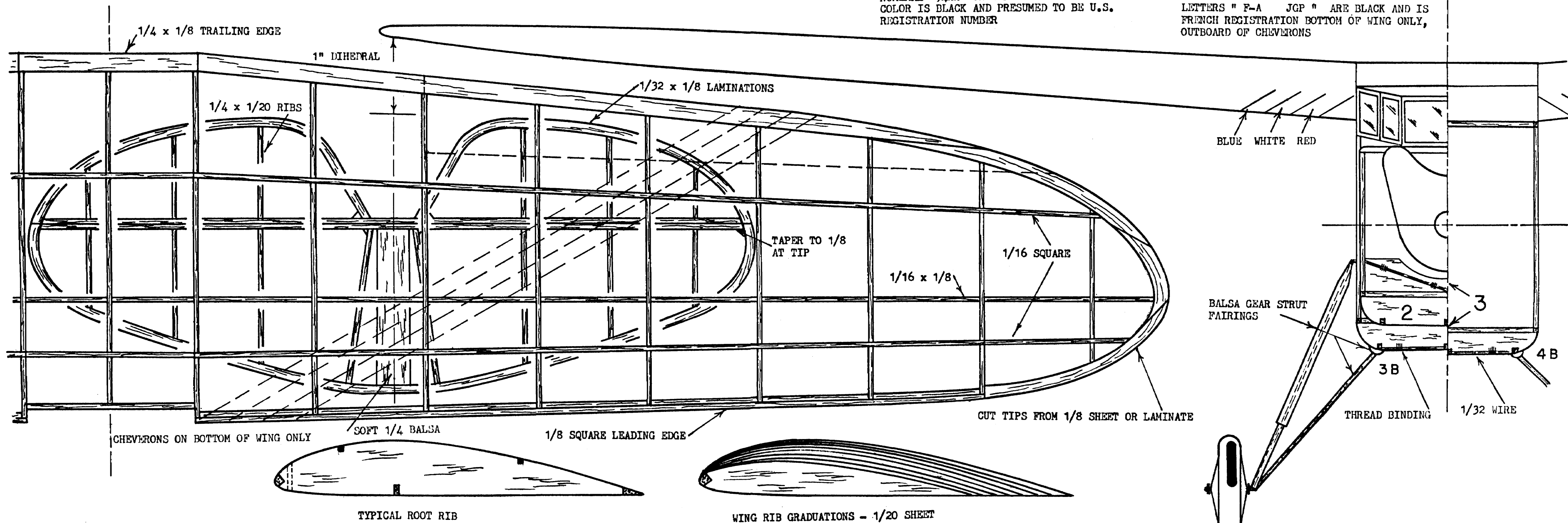

SOURCE OF DATA FOR THIS MODEL IS
 ATLANTIC WINGS 1919 - 1939, by
 KENNETH McDONOUGH, MODEL AERONAUTICAL
 PRESS, HEMEL HEMPSTEAD: Herts, U.K.
 Publication date is 1966

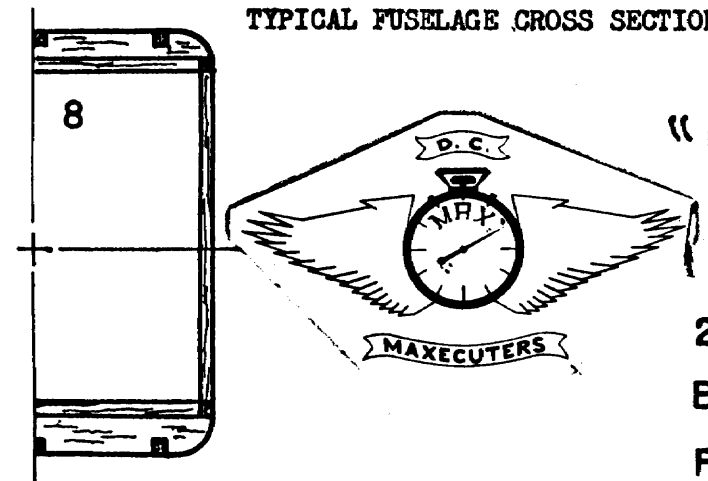

"L'OISEAU CANARI"
 BERNARD 191 GR H2
 28 1/2" WINGSPAN, 20 1/2" LENGTH
 BY COL. HURST BOWERS, APRIL '87
 FOR MAXFAX