

First Raid WWI—Avro-504

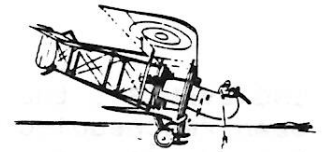

Combat Dive-Bombing—1915 Farman



Boeing F4B-4



Curtiss BF2C-1

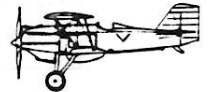

Curtiss F6C-3



Curtiss F11C-2

MAX - FAX

THE NEWSLETTER OF THE D. C. MAXECUTERS
SEPTEMBER/OCTOBER 1990

MEMBERSHIP

Dues for membership in the D.C. MAXECUTERS is \$10 per year for residents of the USA, Canada, & Mexico, and \$11 for all other countries. Your mailing label indicates the last year and month for your current membership. A red X next to the label is a reminder that your current membership has ended. Send a check, payable to the D.C. MAXECUTERS, to the Treasurer.

MEETINGS

The D.C. MAXECUTERS hold meetings on the first Wednesday of every month at the College Park Airport.

PRESIDENT

Bert Phillips
1709 Crofton Parkway
Crofton MD 21114

SECRETARY

Ernie Greene
8103 Falstaff Rd.
McLean Va 22102

TREASURER

Scott Paisley
20 Clearwater Ct.
Damascus MD 20872

UPCOMING EVENTS

- September 9 : NEW DATE!!! MAXECUTER's Summer Fun Fly, Comsat.
- September 29 : FAC Contest at Raeford (Fayetteville) NC. See Club News.
- November 3 : Indoor Contest at PAX River. See Flier this issue.
- March 30 1991 : Indoor Contest at PAX River.

CLUB NEWS

ALLAN SCHANZLE

THE DREADED RED "X" IS IN
A NEW LOCATION

The use of envelopes has created a need for a new location for this feared piece of memorabilia. If I were to take a poll, I'm sure I would get some interesting suggestions on where I could put this world famous mark. But let's be

reasonable. Look on the envelope, next to the mailing label. That will be the location for your dues due indicator until further notice.

DON'T FORGET, THE SUMMER
FUN FLY IS ON SUNDAY

As noted in the last issue, and reiterated above under "UPCOM-

ING EVENTS", the SUMMER FUN FLY has been rescheduled on Sunday, September 9, rather than Saturday, the 8th. See the flier in this issue.

THE FAC NATS, ANOTHER
MEMORABLE OCCASION

If you weren't there, or couldn't make it, you missed another fine contest. To CD Vic Didelot, Assistant CD Ralph Kuenz, and Contest Manager Lin Reichel, I doff my hat. It was just 2 years ago that I CD'ed the affair, and the level of effort is still fresh in my mind. Thanks fellows, you did a good job.

ANOTHER FAC CONTEST IN
FAYETTEVILLE NC

Dave Rees is going to sponsor an FAC event in North Carolina this year on Saturday, September 29, but this time, he has added a few new twitches. The events will include FAC Scale, FAC Power Scale, mass launch events for WW-I, WW-II, Golden Age, and Peanut Scale models, and Old Timer Rubber. An entry fee of \$4.00 will not only get you into the contest, but also a lunch and iced tea. On top of this, Dave will sponsor, in his NEW backyard, an ROW event from 5:00 PM to dark on the Friday night before the scheduled contest. And if that isn't enough, tack on a dinner after the ROW affair for all contestants. All this at Dave's new residence at 606 Walnut Creek Dr., Goldsboro NC, 27534.

INTERSCALE '91, AN INTERNATIONAL
INDOOR SCALE CONTEST IN ENGLAND

In the last issue, I included a last minute notice concerning an activity by our British friends,

which they call INTERSCALE '91. This will be an international indoor event for rubber and CO₂/Electric models and held on September 21st and 22nd, 1991 (next year). The location is the Sports Complex at the University of Nottingham, England. To the best of my knowledge, there is no truth to the rumor that Robin Hood will high in the rafters to thrust his trusty arrow through all non-British aeroplanes. The information was sent by one of our subscribers, Reg Boor, who is on the INTERSCALE '91 committee. He has forwarded an extensive package of rules and general information. If you are serious about attending, send me a self addressed and stamped envelope (45 cents, not 25 cents) and I'll copy the information and forward it to you. If you want to contact Reg directly, his address is:

Reg Boor
103 Crow Hill South
Middleton, Manchester
England M24 1LA

Please include at least two international postal certificates if you request information.

THIS ISSUE

This issue features a plan of the Miller Zeta. The real aircraft hangs in the Springfield MA museum. The plan requires 8 pages, so this doesn't leave much space for other material. But for all you FAC fanatics, we include, as is our tradition, four pages of photos taken at the Geneseo affair. The next time you see Tom Schmitt, give him thanks, because he is the one who stands in the dark room for endless hours so you fellows and gals can envy a multitude of the models that were on display. Many thanks, Tom. Don't forget, we'll see you at Comsat on Sunday, September 9th.

D.C. MAXCUTER'S '90 SUMMER

FUN FLY

Sept 9

AMA SANCTION 1036

CONTEST DIRECTOR
ALLAN SCHANZLE
20008 SPUR HILL DR.
GAITHERSBURG MD. 20879
(301) 840-5884



9:00
to
5:00

EVENTS

FAC SCALE: Judging starts at 11:30 AM. Qualifying flight must be made by this time.
FAC POWER SCALE: Qualifying flight by 11:30 AM.
PEANUT SCALE: Mooney judging. The CD has declared.....
NO FIKES OR LACEYS ARE ALLOWED!!!!!!
Qualifying flight by 11:30 AM.

MASS LAUNCH:

The Races 1:00 PM. A single launch for all racers.
WW I 2:00 PM. Multi-wings only.
WW II 3:00 PM.
Golden Age 4:00 PM.

EMBRYO: FAC rules.
H.L. Glider: AMA rules.

INDOOR MODEL AIRPLANE CONTEST

NAS/NATC PATUXENT RIVER - LEXINGTON PARK, MARYLAND
HANGAR VX-1
SATURDAY NOVEMBER 3, 1990
9:00 AM - 5:30 PM

NO ENTRY FEE BUT DONATIONS TO THE NAVY RELIEF SOCIETY ARE WELCOMED

MAJOR EVENTS (FAC Rules & Trophies awarded)
MASS LAUNCH OTHER EVENTS
1- OLD TIME SCALE* 11:00 AM 6- FAC RUBBER SCALE
2- WW-I 12:00 PM 7- COCONUT SCALE**
3- NAVY SCALE 1:00 PM 8- BOGUS SCALE BOSTONIAN
14 GRAMS MINIMUM WGT.***
4- PEANUT SCALE 2:00 PM (See rules in Nov-Dec 89
MAX-FAX)
5- GOLDEN AGE 3:00 PM

SPECIAL EVENTS (Buttons awarded)

1- WALT MOONEY COMMEMORATIVE PEANUT SCALE - Walt's Rules.
2- FAC INDOOR POWER SCALE (CO2 and MINI ELECTRIC).
2- NOVICE PENNYPLANE (AMA Rules)***
* OLD TIME SCALE RULES - Any old time kit plan; vintage before December 31, 1942 with 20 inch wingspan or less.
** COCONUT Rules - 1 oz minimum weight w/o motor
Minimum wingspan - monoplanes 36 ins., - multiwings 30 ins.
Judging - 30 point maximum scale points added to flight time in seconds for total score.
*** Single best flight time determines winner in these events.

PROVISIONAL EVENTS (Buttons Awarded)

1- NOCAL (6.2 gram minimum weight)
2- 7 Gram BOSTONIAN
Bill Clarke is Event Judge for these events.

AIRCRAFT FOR SCALE JUDGING MUST BE TURNED IN BY 11:00 AM

NO QUALIFYING FLIGHT IS REQUIRED
ALL FLIGHT TIMES MUST BE SUBMITTED BY 4:30 PM DEADLINE
AWARDS: 5:10 - 5:30

LOCAL RULE: ONLY ONE MASS LAUNCH EVENT PER AIRCRAFT

CONTEST INFORMATION: CLAUDE POWELL 1 (301) 872-4105
ALLAN SCHANZLE 1 (301) 840-5884
TOM SCHMITT 1 (301) 530-0327

IMPORTANT NOTICES:

FOOD AND BEVERAGES WILL BE AVAILABLE IN THE HANGAR AT NOMINAL PRICES
PLEASE SUPPORT THIS EFFORT BY THE NAVY
ALSO PLEASE NOTE THERE WILL BE NO TABLES OR CHAIRS AVAILABLE IN THE
HANGAR SO BE SURE TO BRING YOUR OWN.

SPONSORED BY: NAVAL AIR STATION/NAVAL AIR TEST CENTER,
PATUXENT RIVER, MARYLAND AND ST. MARY'S
COUNTY RECREATION AND PARKS.

PHOTO PAGES

Tom Schmitt

FAC NATS Mk VII - National Warplane Museum - Geneseo, New York

1. Fernando Ramos and "Fuddy Duddy", the Museums flying B-17G.
2. A bird's eye (SNB) view of the activities on the great flying site; pilot was our host Austin Wadsworth.
3. Lindsey Smith came all the way from "merry ole" England with his wife Jane to enjoy the festivities; you should see his geared Caudron go.
4. Daren Doman shows the big boys how to do it!
5. Dave Rees flew to a second place by one point in FAC POWER SCALE with his Hi Line electric powered Colibri; Hi Line electric powered aircraft took the top four places in this event.
6. Mark Fineman with a great looking B-17 turboprop test bed aircraft.
7. Ray Rakow finished and flew his Mr. Smoothie the day of the race event.
8. The winner in FAC POWER SCALE, Don Srull's DO-X with 6 Hi Line motors.
9. Pat Daily with his high flying 3rd place Hurricane, powered with a prototype Hi Line Mini-12 dual electric motor.
10. Earl tries his hand with a Stahl Hurricane built by Bud Carson.
11. A great flying CO2 powered Westland P-12 by Joe Barrish.
12. Hurst Bowers adapted a Hi Line Mini-6 motor to this handsome Earl Stahl Stinson O-49 and had some beautiful flights.
13. Harvey Hopkins and his very pretty Boeing tri-motor.
14. Bud Carson with his electric powered Jodel D-9.
15. Dave Stott winding his SBC-3 for a second place in the MILITARY BIPLANE event; Dave also walked off with the much coveted "EARL STAHL" trophy for his Bristol Brandon. See a recent MAX-FAX for plans.
16. Dan Briehl took a second in the GREVE event with his Chambermaid.
17. That genial twosome Kevin Sharbonda and Bill Bell with Bill's Stearman.
18. Vance Gilbert brought along this pretty AVRO 547. Also his Short took 3rd place in JUMBO and won the ACHIEVEMENT trophy.
19. Don Srull's Letov for the GOLDEN AGE SCALE event.
20. Vance flew this beautiful CANT Z-506a to 6th place in JUMBO SCALE.
21. Allan Schanzle with his pretty little CO2 powered Hummel. A full size plan will be in next issue of MAX-FAX.
22. Don launching his Keith-Rider R-4 in the GREVE event.
23. A high flying Earl Stahl Hi-Climber by Mark Fineman.
24. Another aircraft by Mark, this beautiful JUMBO Savoia Marchetti 92.
25. An electric powered Fairchild amphibian by Joe Barrish.
26. Eric Dittman came all the way from the Northwest to fly his diesel powered Longster Wimpy.
27. Bill Bell works on his Cox 02 powered Guillow Stearman.
28. Bill finally did get it flying.
29. Tom Arnold from San Diego with a twin Mustang.
30. Gordon Roberts winds his Fairey Fantome for the MILITARY BIPLANE event. *Where are the markings and control surfaces Gordon???*
31. Jack McGillivray winds his SE-5 long nose for the WWI DOGFIGHT.
32. One of the three SBC-3's, this one by Don won the MILITARY BIPE event.
33. Bob Thompson holds for Mark "oh please, just 5 more turns" Fineman.
34. Dave Stott gave the *bumblebees* a run for the money in the THOMPSON event with his very pretty Laird.
35. John Houck winding his JUMBO Der Cricket; Mark holding.
36. Tom Nallen with a very pretty JUMBO Fleet.
37. Mike Midkiff with his PEANUT Hergt Monoplane.
38. Dan Driscoll, John Low and Pat Daily feeding John's Stearman.
39. Last but certainly not least, this is what FAC should be all about! Dave Stott's grin tells all; *this is fun - wait til '92!*

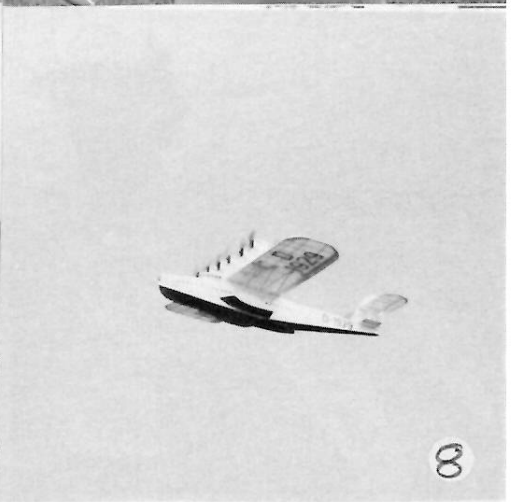
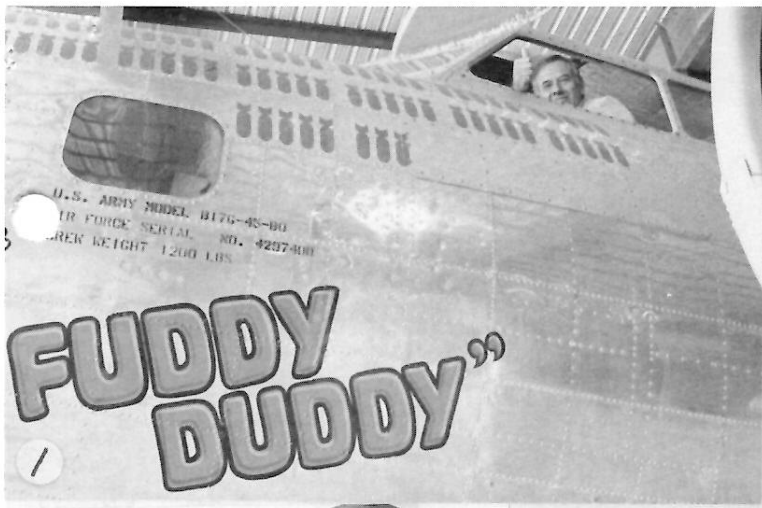

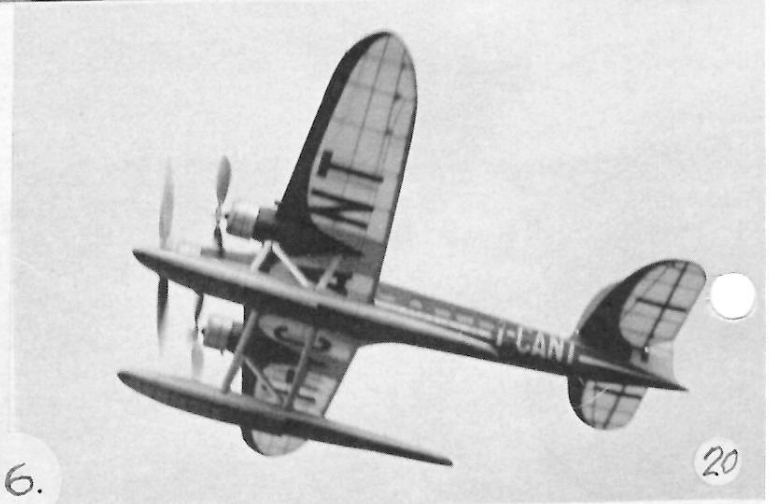
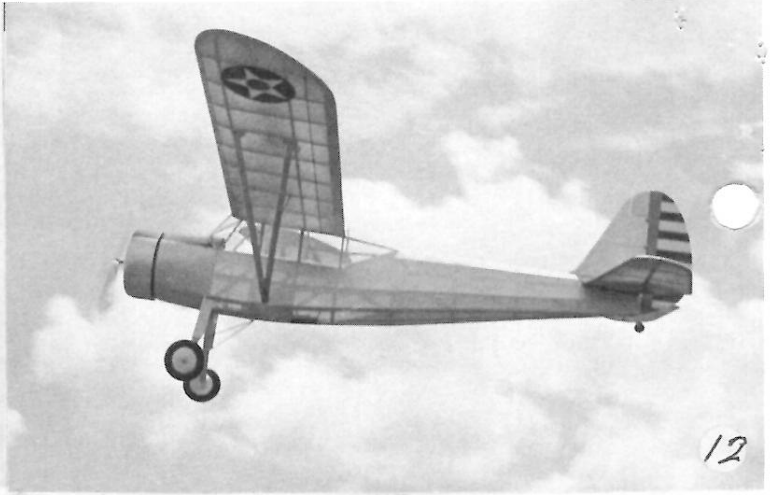
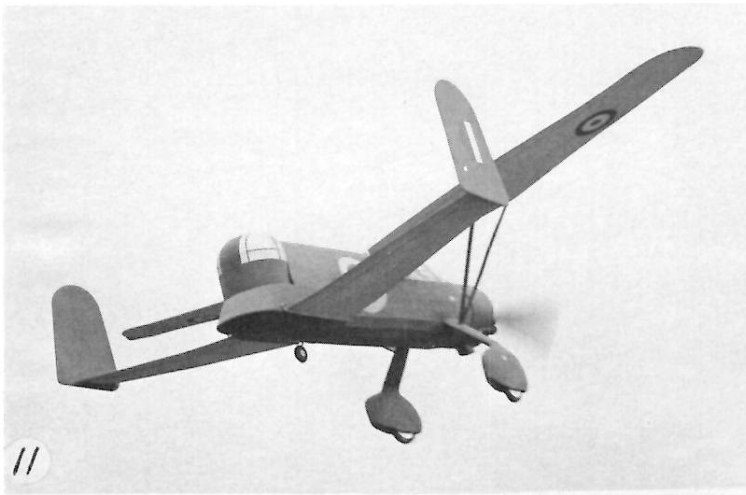

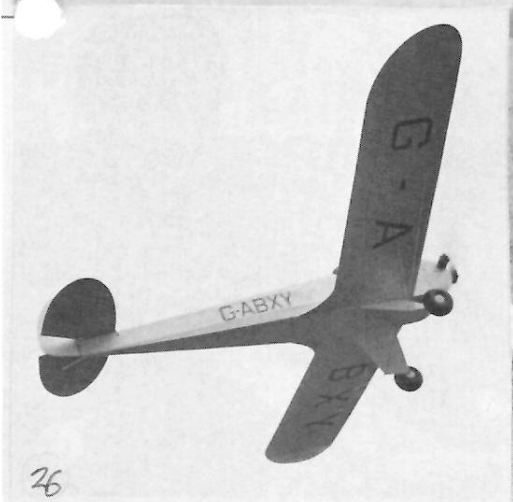
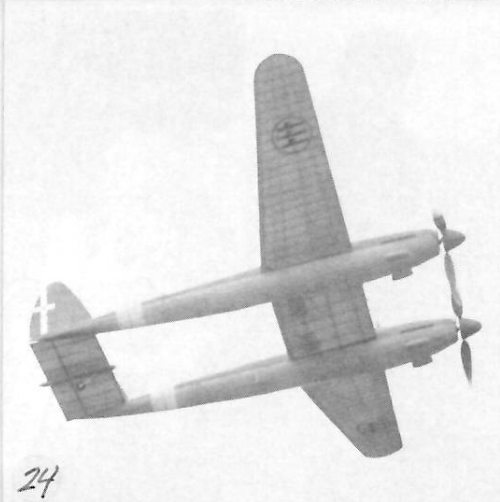
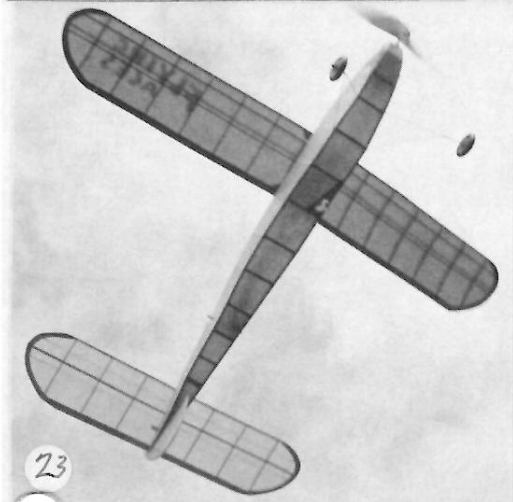
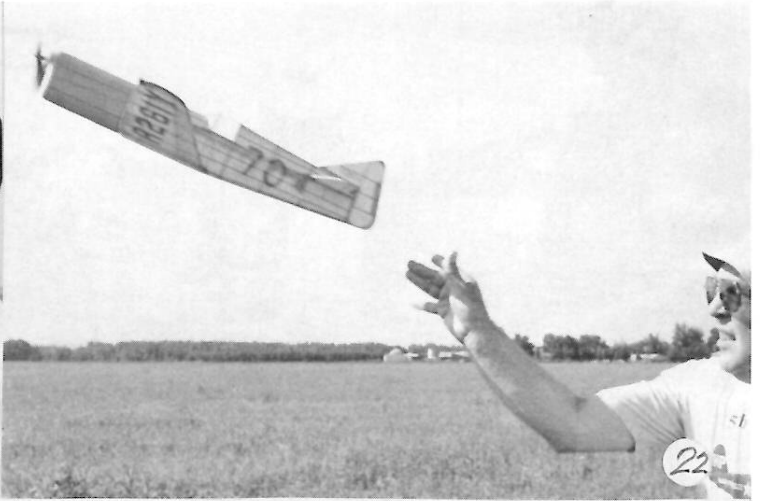



MILLER "ZETA"

AS DRAWN BY GORDON VAUGHAN, 1-29-38

3/4" SCALE

J. BLAIR 6-79

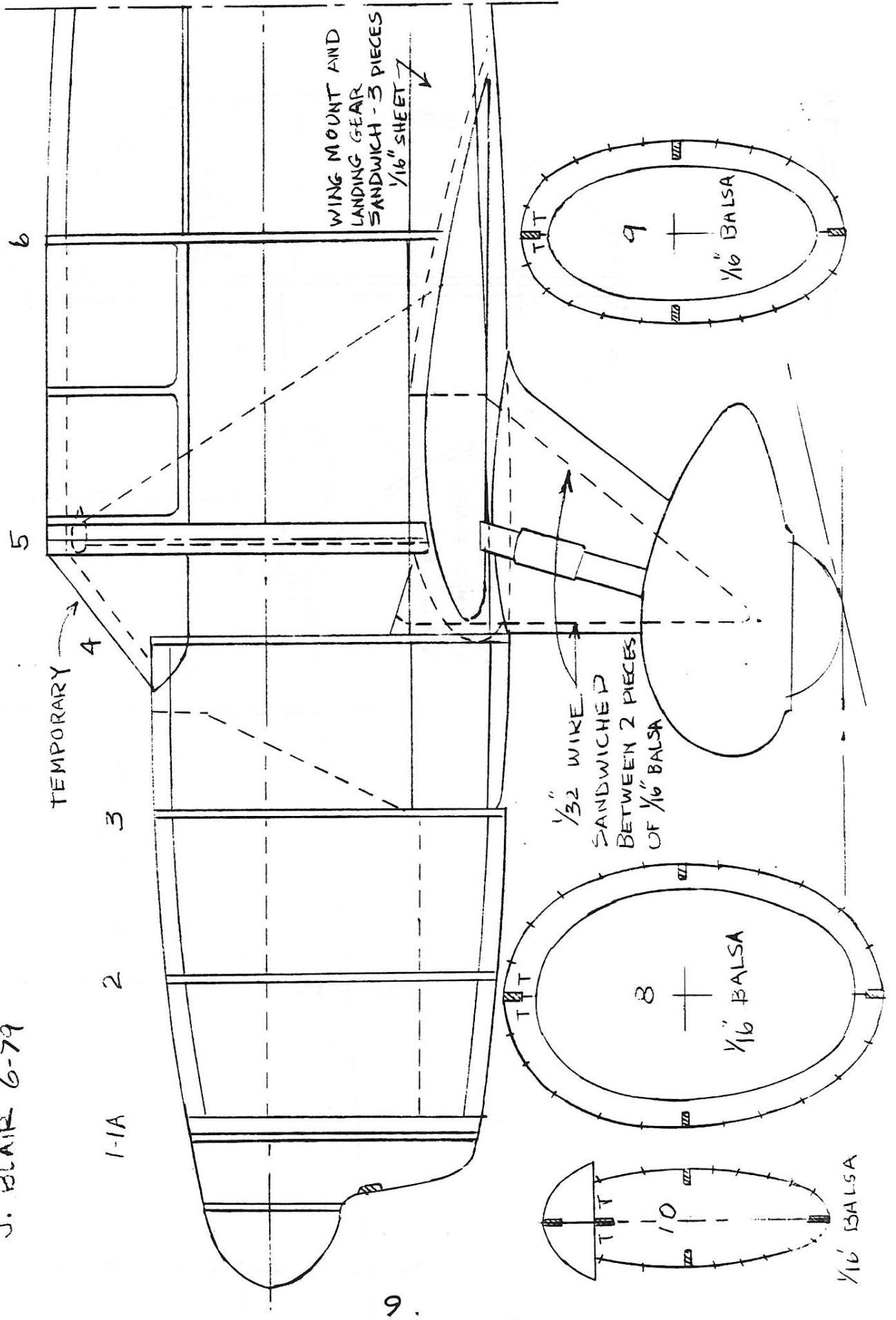

MILLER "ZETA"

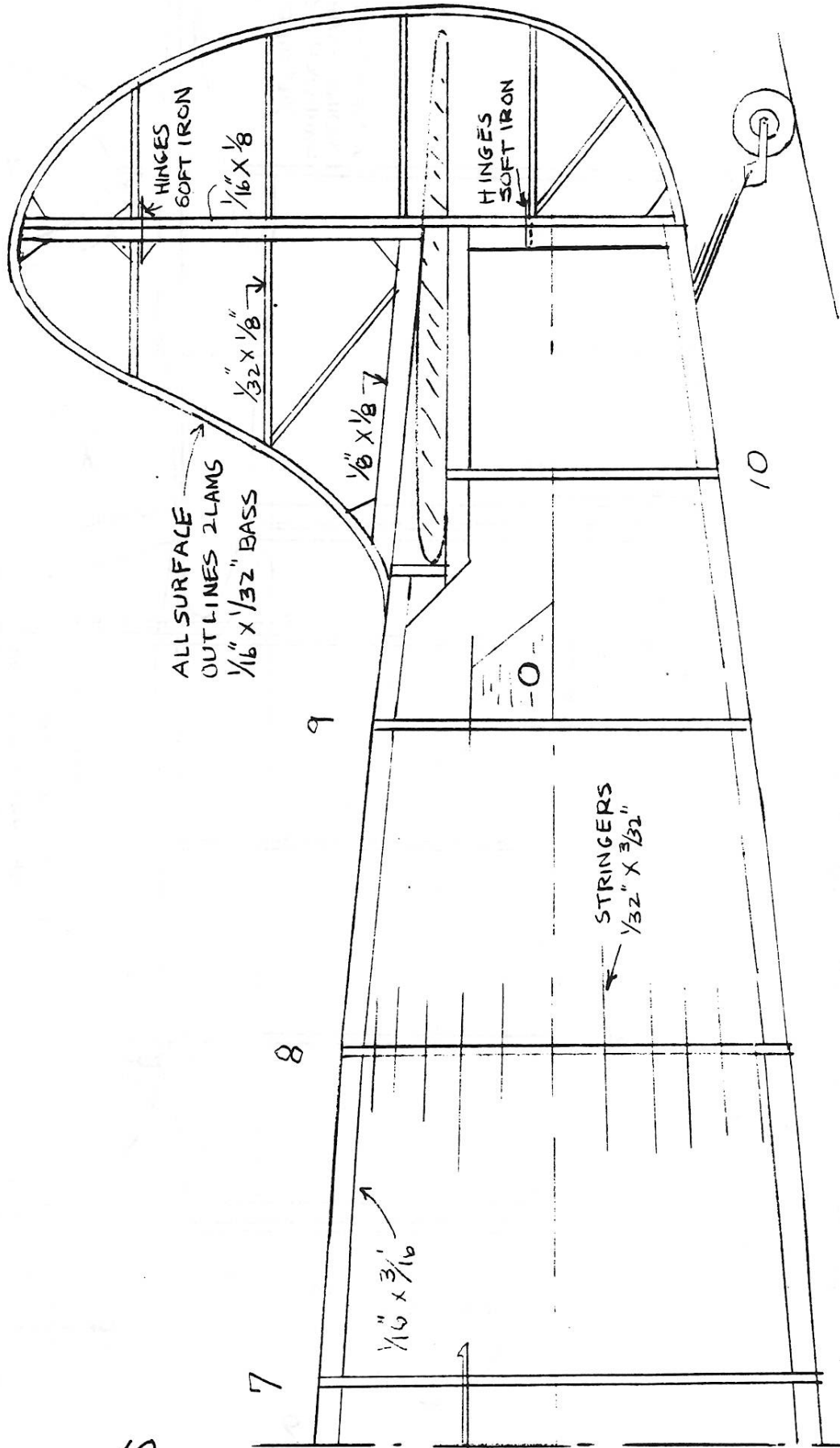

10.

7

8

9

10

$\frac{1}{16} \times \frac{3}{16}$

STRINGERS
 $\frac{1}{32} \times \frac{3}{32}$

ALL SURFACE
OUTLINES 2 LAMS
 $\frac{1}{16} \times \frac{1}{32}$ BASS

$\frac{1}{32} \times \frac{1}{8}$

$\frac{1}{16} \times \frac{1}{8}$

HINGES
SOFT IRON

$\frac{1}{16} \times \frac{1}{8}$

HINGES
SOFT IRON



MILLER ZETA

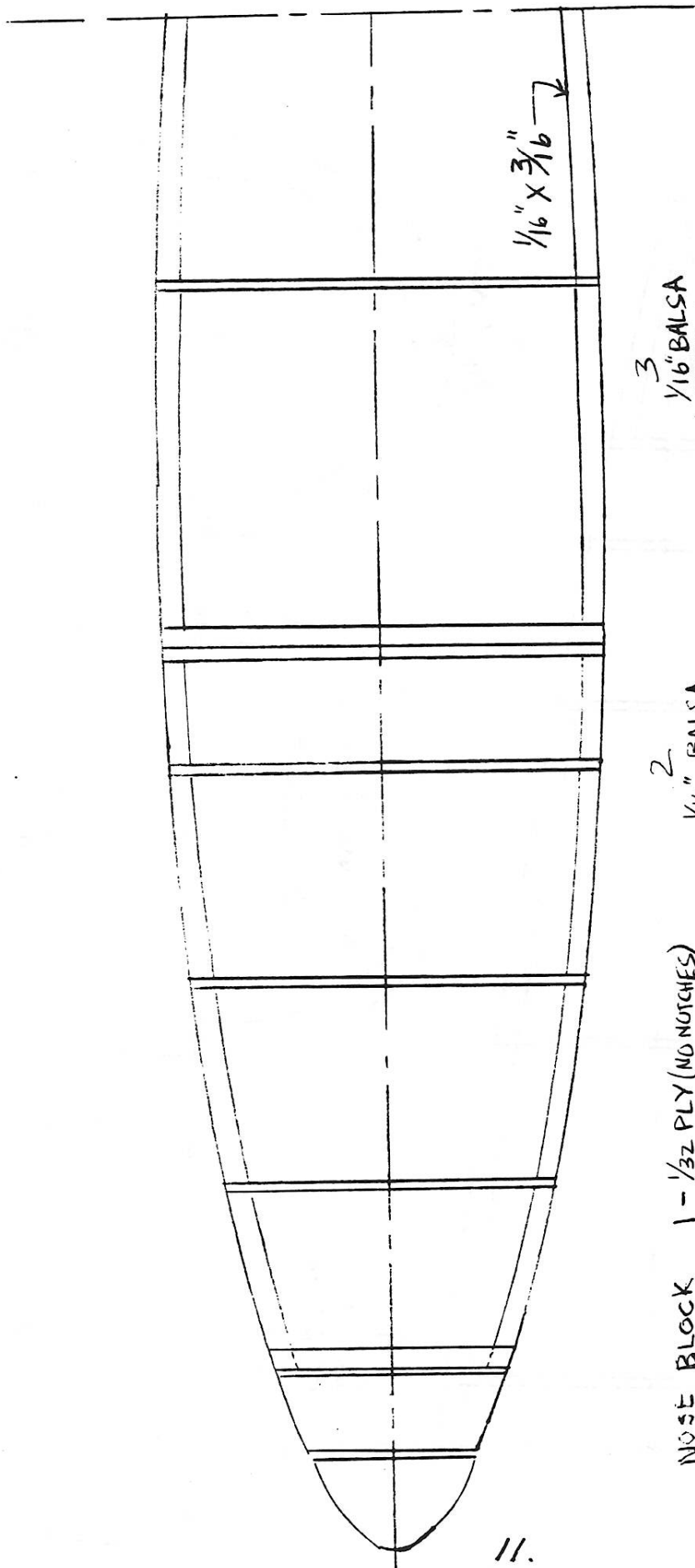

11.

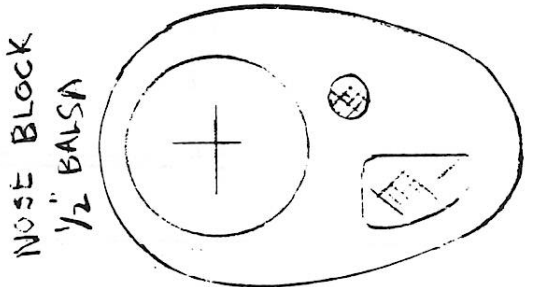
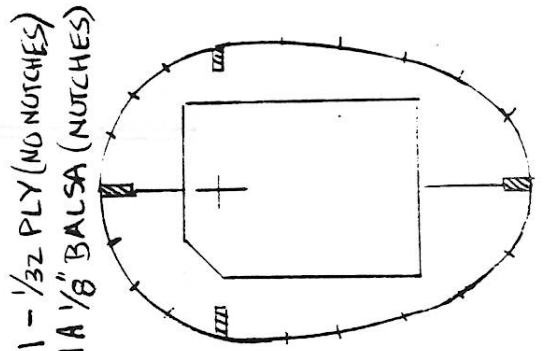
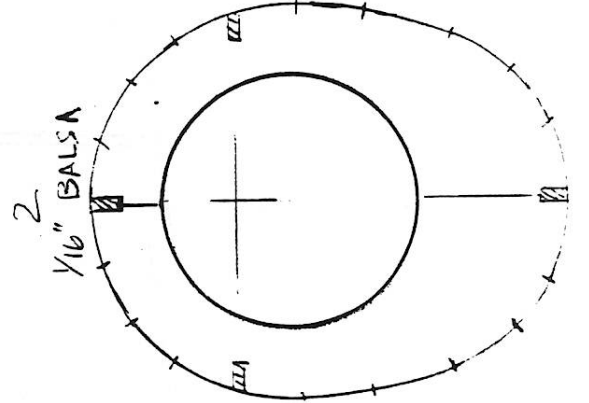
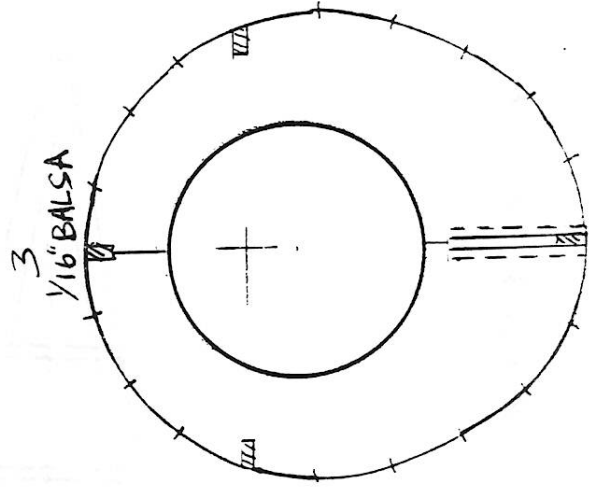

MILLER ZETA

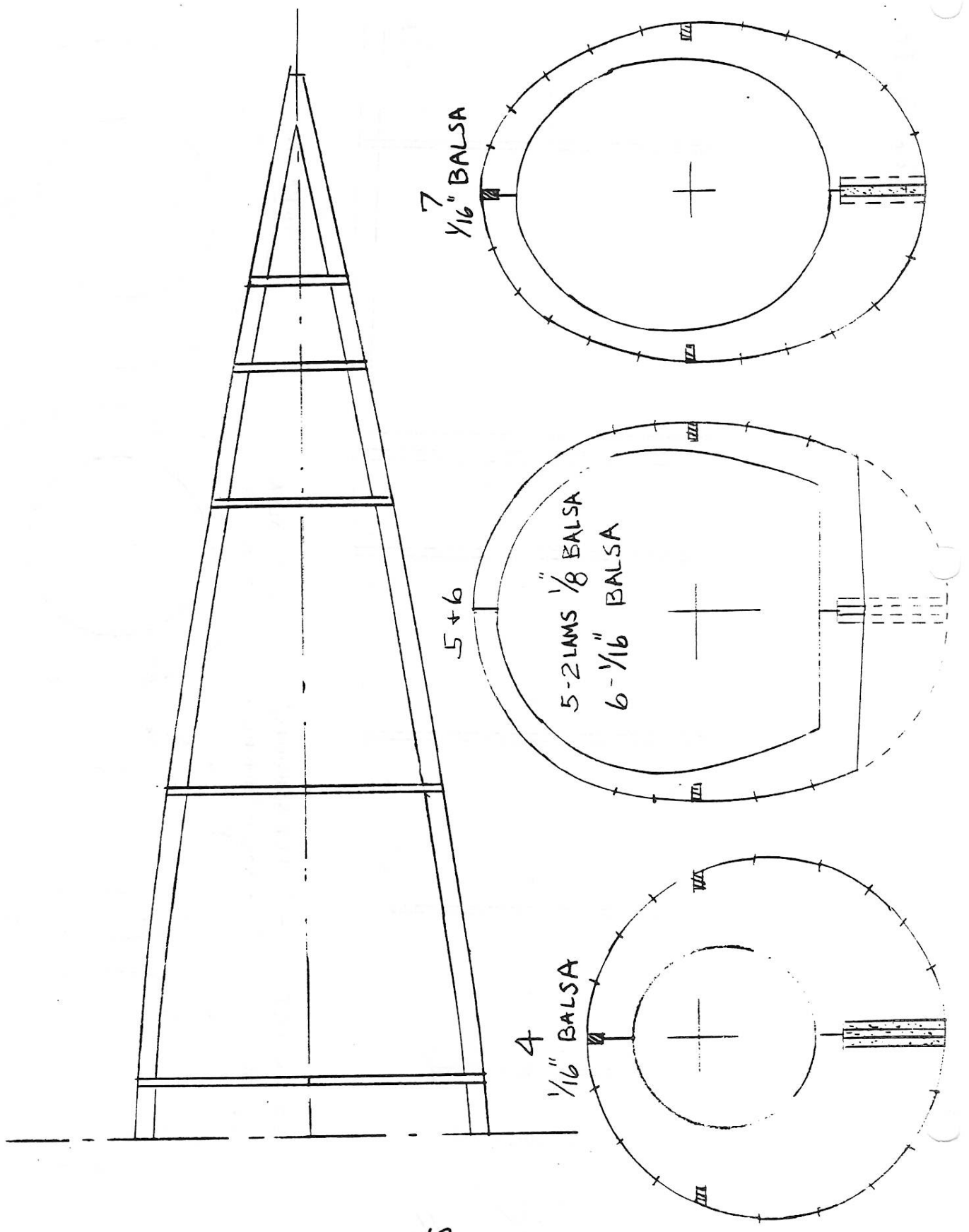

MILLER ZETA

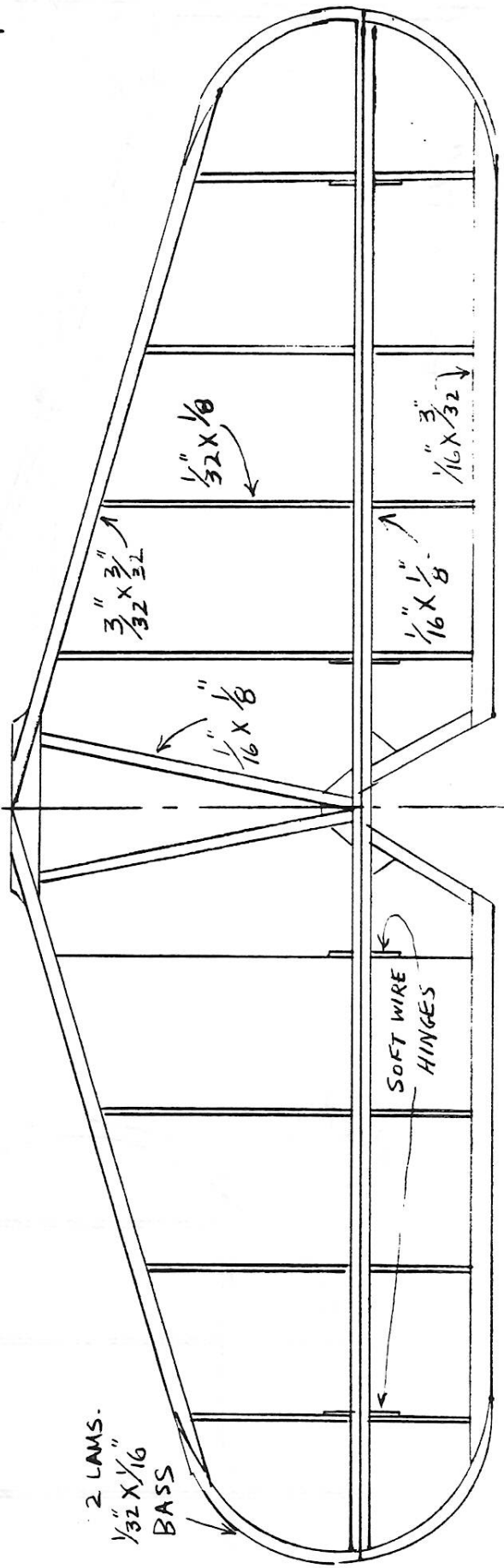
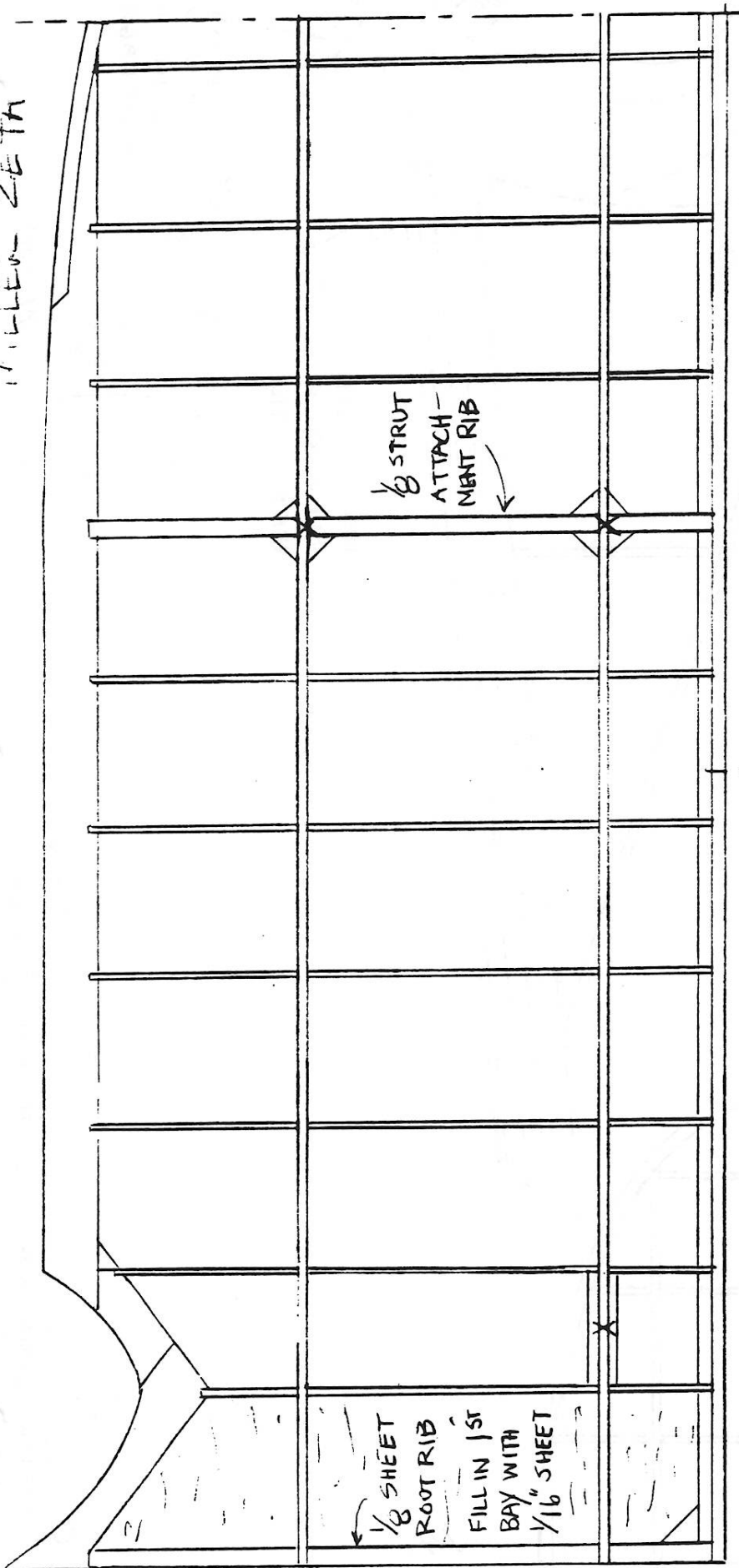

13.

MILLER ZETA

3 LAMS.
1/32" X 3/32" BASS.

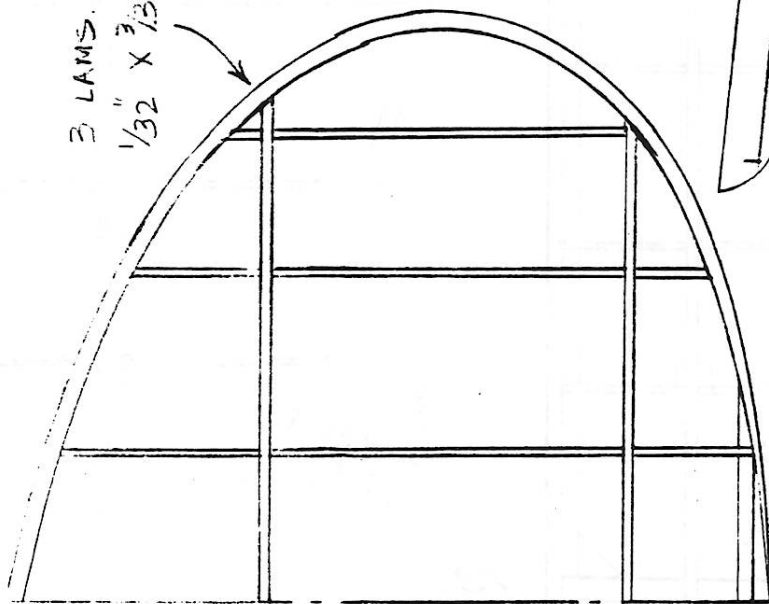

MAKE THIS STRUT TELESCOPE FOR SHOCK ACTION

DO NOT. GLUE WOOD FAIRING TO FUSELAGE

3/4" SCALE

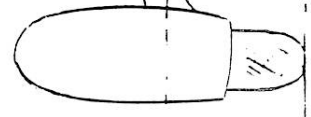

TYPICAL WING RIB: MAKE 4 FROM 1/8" SHEET, 24 FT 1/32" SHEET. TRIM TIP RIBS TO FIT

MILLER "ZETA"

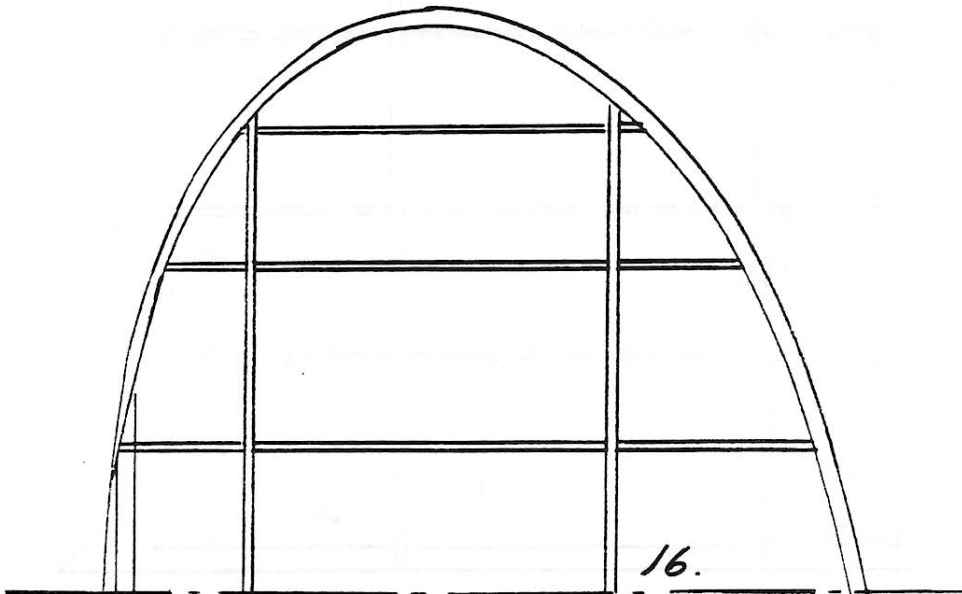
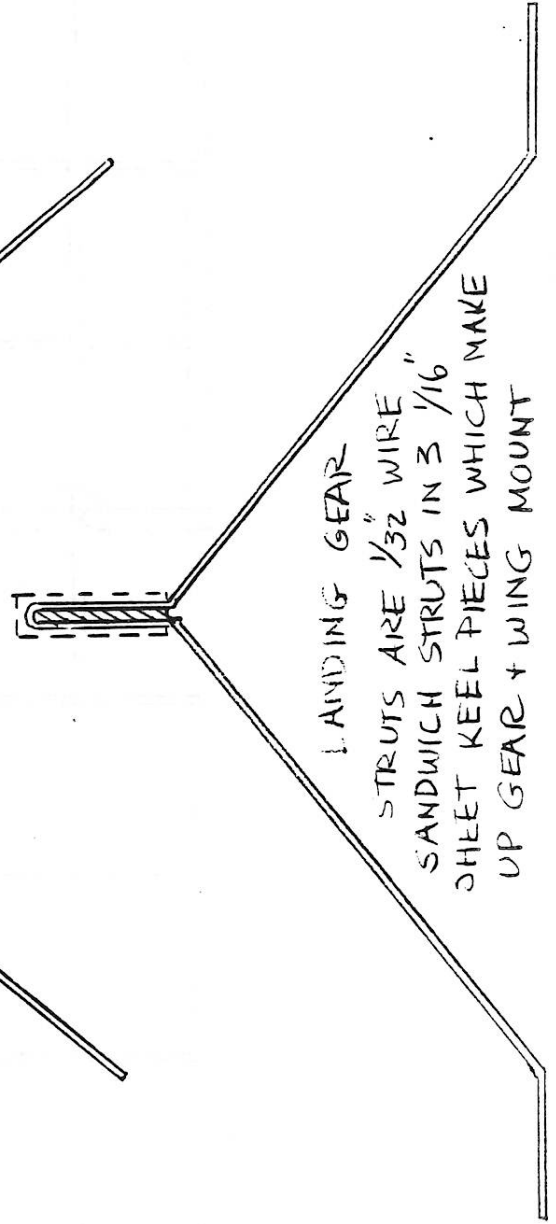
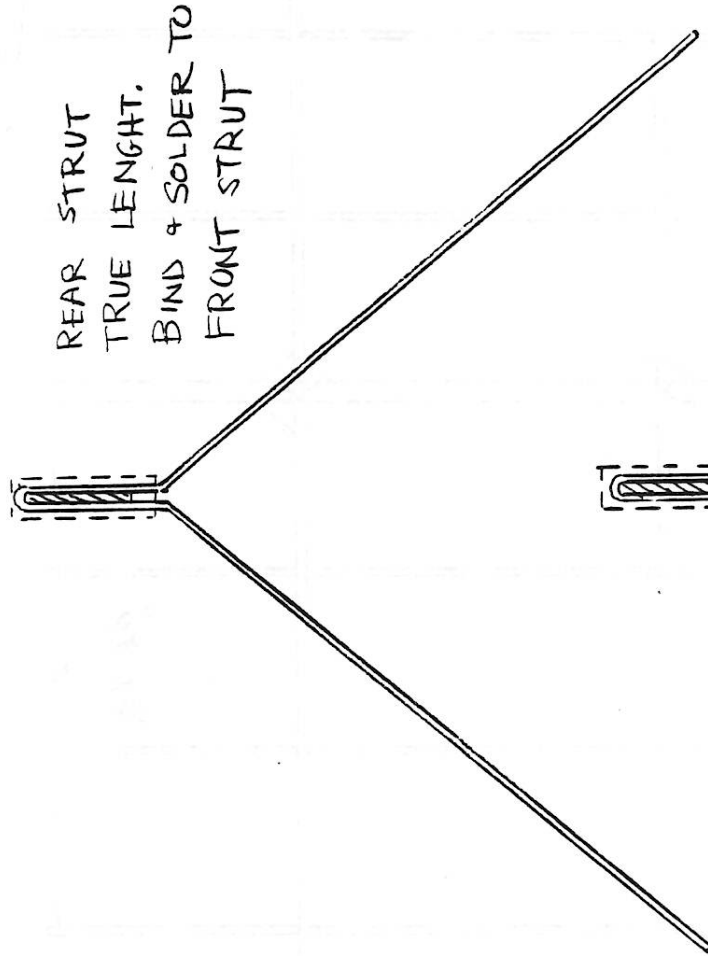

The Zeta

Tom Schmitt et al

The featured plan arrived in a roundabout path. It was sent to us from Claude Powell several years ago. He had received it and a three view from Bob Wedell. Let us directly quote Bob for the history and origin of the plans.

"There is a little story behind the plans (three view) drawn by Gordy Vaughan back in January of 1938. Gordy was a member of the Southern SOTS when we started that club back in 1978. Then Gordy passed on when the bypass didn't take. He was a real spark plug but he just smoked too much and his blood vessels couldn't take it. He was 61.

"John Blair then took the three view and drew plans for the free flight you see here. Maybe a little more dihedral might help the flight characteristics.

"Another interesting sidelight is that Gordy built models of the GeeBees for the Granville Brothers as he lived only a couple of blocks away from where they built them in Springfield, Mass.."

Some final notes are in order. After laying dormant in hidden club archives for several years, Bill Ceresa undertook the labor of love to trace the full plans on to page size sheets for our newsletter. Finally, for you avid scale buffs, the original machine hangs in the Springfield Museum and is readily accessible for all angles of photography. Tom Nallen has thoughtfully provided a factory three view which illustrates the strut support system within the canopy. See Tom's note cards sold by Bill Hannan for a great sketch of the "ZETA".

OLD TIMER RUBBER CONTEST RESULTS

Allan Schanzle

The weather wasn't exactly the best, but boy, what a bunch of wimps we have around here. Only four fellows showed up with old time models. We had a single mass launch to determine the winner. About one half second after launch, there were only two still in the air. Doug Buchanan was to my left. His model turns to the right, and guess whose model turns to the left? His wood prop ate right through the fuselage of my Flying Aces Moth, and then chopped the wing in two pieces. Dan Driscoll's Pacific Ace and Rolf Gregory's Flying Aces Moth continued, with

Rolf landing first. So Dan was the winner, but the wind blew the bloody fool thing into the trees, about 50 feet up. It hung on the end of a branch, and we expected the wind to blow it down. But of course, it didn't. The next day we had a 70 mph wind storm that just had to drop the model to the ground, but unfortunately, about 3 feet of rain accompanied the wind. I haven't seen the model, or Dan, for the past few weeks, so I assume the thing blew into the next zip code. Tough break, Dan, but at least you got a Kanone.

OLD TIME RUBBER WINNER DAN DRISCOLL

Notes

4° dihedral
Color Scheme Dark Grey Forward Stripes
Chinese Red Tailings
AND EMPANAGE
Alternate on Lettering
Propeller, Wood.
Exhausts on Right-cowl
Powered By Menasco pinacote 95hp

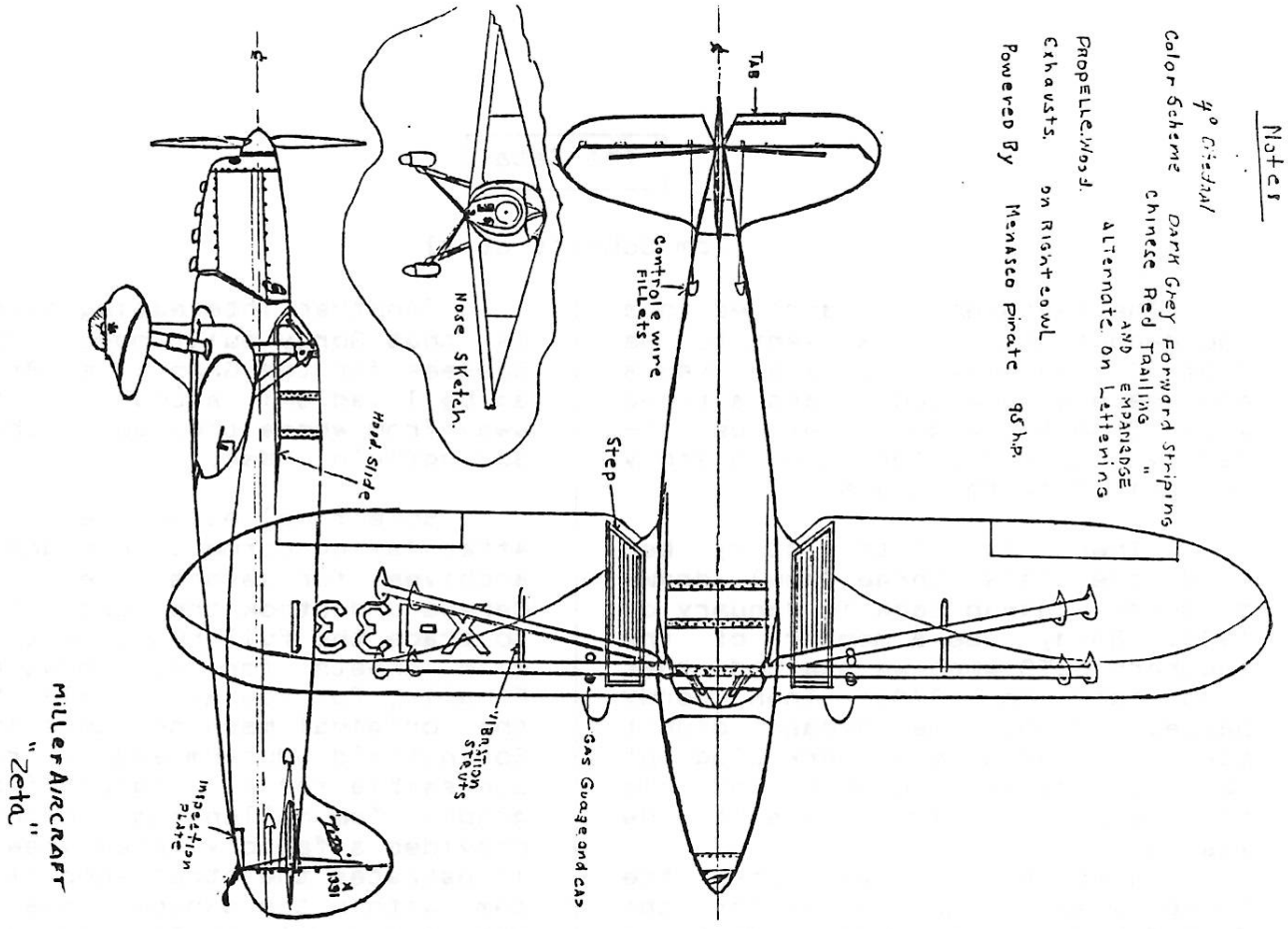

SEPT '90
OCT

max-fax

