

# MAX FAX



Journal of the D. C. Maxecuters

...home of the dreaded POTOMAC PURSUIT SQUADRON of the Flying Aces Club

Editors: Tom Schmitt & Don Srull

January—February 1995



## COMING ATTRACTIONS

- JANUARY 7 **Saturday Flying** - Sherwood HS Main Gym- 6:00 to 9:00pm -BOSTONIAN Contests (BOGUS SCALE and STANDARD 14 GRAM).
- 
- JANUARY 8 **CAAMA/MECA Reg 11 Collecto** - Pimmit Hills Library - 7584 Leesburg Pike - Falls Church ,Virginia - 1:00 to 5:00pm - For INFO call Marty Schindler (703) 938-2975.
- 
- JANUARY 14 **Bull Session** at Pat Daily's home about 5pm preceded by a 1pm visit to the Air Museum at RIA. ;See map in this issue.
- 
- JANUARY 21 **Saturday Flying** - Sherwood HS Main Gym - 6:00 to 9:00pm -CARRIER LANDING Contests (Navy Scaleand Other Aircraft).
- 
- FEBRUARY 3 **Friday Flying** - Sherwood HS Alternate Gym - 7:00 to 10:00pm -NO-CAL Contest.
- 
- FEBRUARY 18 **Saturday Flying** - Sherwood HS Main Gym - 6:00 to 9:00pm -OLD-TIME KIT SCALE (10 center Contest, Includes AIRDEVIL MODEL CO. designs).
- 
- MARCH 3 **Saturday Flying** - Sherwood HS Main Gym - 7:00 to 10:00pm -POTPOURRI SCALE Contest.
- 
- MARCH ?? **PAX RIVER INDOOR CONTEST** - date uncertain - Check in the next MAX/FAX or with Claude Powell (301-872-4105) or Tom Schmitt (301-530-0327).
- 
- MAY 6 **Indoor Contest** - Saturday at Reading, Pennsylvania - Contact Tom Hallman (610) 395-5656.



**1995 ALREADY?!** Hard to believe, eh? To help get the new year started at full winds we have a few nifty items for this first '95 issue of MAXFAX. It's kind of a mostly multi-motor, rubber-powered, seaplane issue. First off, we have a great full size plan from our good friend and incredible craftsman, Paul Boyanowski. If you saw his beautiful and unusual Short S.26 rubber powered flying boat at the FAC Nats last year, our feature plan will show you how it was done. We also include a set of the old "Cleveland Amphibian" plans - a semi-scale rendition of the Sikorsky S-38. And finally, a neat little item from the summer of '78 Air Trails, Louis Garami's little amphibian, "The Duck". A few more novelties plus the usual terrific photo pages by Tom Schmitt round out this Happy New Year's offering.

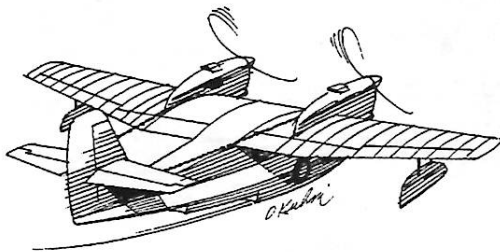

---

---

## RAEFORD RAVES

---

---

We have in the past written so many glowing words concerning the great fun-flys in North Carolina that we run out of adjectives to describe another weekend there. Those who attended the latest on

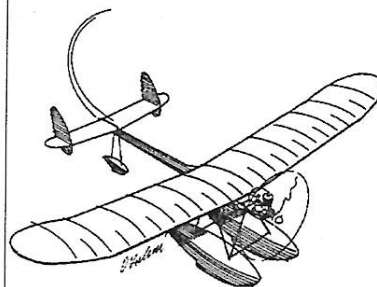

October 7 and 8, 94 will attest to the fun that an FACer can have there. Those who do not attend these bashes are missing some of the best weekends of their lives. This year the weather again was near perfect

and the flying the greatest. Even those of us who gave up aircraft to "HUNG" did not have our spirits dampened. There was one damp spirit though; we inducted another flyer into the "dunkee" squadron. Our own Capt Pat joined Jerry Paisley in examining the bottom of Dave and Marie's lake from the inside of an inverted aircraft carrier (canoe)! We should mention he did not even become flustered since he arrived on the surface with his cigarettes in hand! Sorry, no photos this time. Again thanks to Dave and Marie Rees, and Tom Odum for making all this be a happening. Take a look at some of the photos for a glimpse of the fun.

---

---

## C.A.V.U. REVISITED

---

---

We hope that all our readers enjoyed the C.A.V.U. article by Nancy and Rolfe Gregory in the May/June 94 MAXFAX. A photo was omitted because of lack of space that may be of interest to some of you DH-6 fans out there. It is included here for your files. It is one of the OX-5 conversions done in New Jersey by the Chamberlin and Rowe Aircraft Corporation. It is entirely possible that Tom Connolly assisted in its restoration. This one is unique in that the aircraft's nose is somewhat streamlined with an attractive metal cowling. It appears that the radiator may be mounted between the fuselage and the upper wing. Perhaps someone out there has more information on this version. Maybe with a little encouragement we can get Nancy and Rolfe to author some more articles for the newsletter.

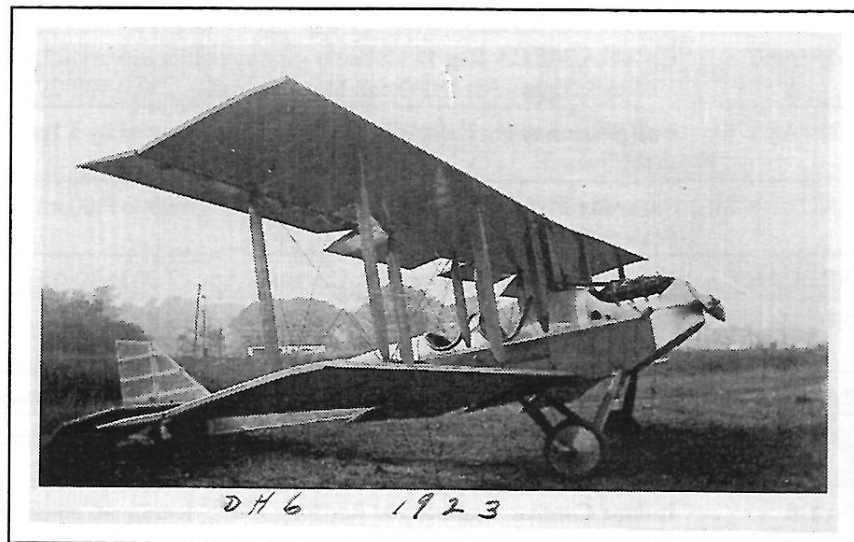

## CONTRA-ROTATING PROPS

In the July/Aug. 94 issue of MAXFAX we included a photograph of Jiro Sugimoto's PEANUT Kawanishi "KYOFU". The "KYOFU" has twin rubber motors and contra-rotating props. It weighs just 11 grams and flies 30-40 seconds. We queried Jiro about his contra-rotating system and he graciously responded with full information including an installation sketch. Since our readers are an inquisitive lot and may have similar projects on their lists we have printed Jiro's sketch below. Lo and behold we were somewhat chagrined to also learn from Jiro that all the info was in our own back yard. Jiro told us he used Mark Allison's cast epoxy gears (18 and 12 tooth) and constructed the gear box in accordance with Mark Allison's instructions. Refer to Mark's article in Flying Models, March 1991; or better yet send him a dollar and a S.A.S.E. for his comprehensive instruction sheet and ask for his price list for gears and gearbox materials. Mark Allison, Route 1, Box K4, Bishop, California 93514.

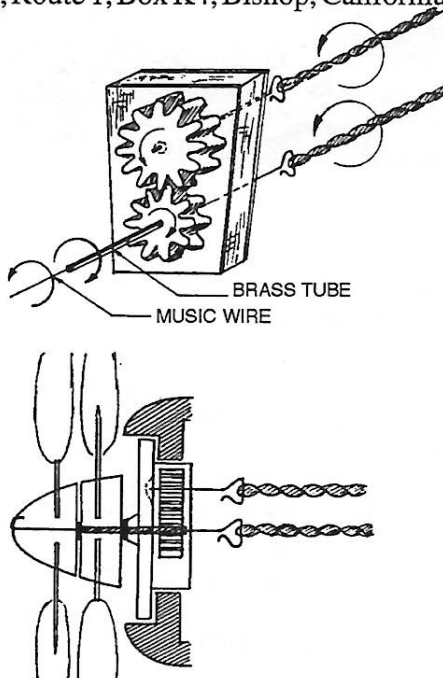

**PLANBOOK**  
of the



**AIRDEVIL MODEL CO.**

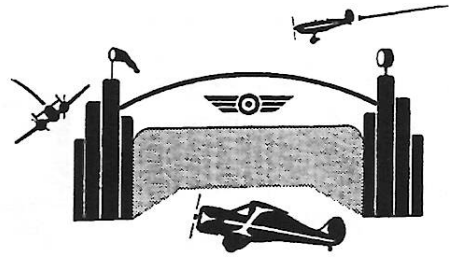

by Dave Stott

Dave Stott, one of our FAC mentors is now the owner and CEO of the AIRDEVIL MODEL COMPANY, a FORTUNE 500 company nestled in the valleys of Connecticut. We believe it was born and nurtured on the plains of Pinkham Field. The company's first product is a book of model plans for little known aircraft not previously modelled. The plans are great and done in a style similar to old-timer 10 cent Comet kits. The book contains 7 plans including the Hollywood Hamilton and Nicholas - Beazley Flyabout (the latter is at Rhinebeck). Dave gives a brief historical summary of each aircraft along with his building and flying instructions. The Connecticut gang allow these designs in their 10 center contests, and we will also at the Pax Old Time Scale contest. Dave is asking only \$10.00, postage paid for the first series book of these great plans. Send for yours now and encourage Dave to continue AIRDEVIL MODEL COMPANY production! THANKS TO VANCE AND "AIRFLOW" FOR THIS INFO.

DAVE STOTT  
4304 MADISON AVE.  
TRUMBULL, CONNECTICUT 06611

### SUNDAY AFTERNOON MINI-CONTESTS AT COMSAT

#### OLD TIME RUBBER MASS LAUNCH OCTOBER 16

CONTESTANT	MODEL	PLACE
Frank Rowsome	Crusader	1
Pat Daily	Pacific Ace 30	2
Mike Graham	FA Moth	3

Pat Daily came all the way from Richmond for this event. The lack of entries was more than compensated for by the great weather and enthusiasm of the contestants and spectators. Frank Rowsome put up a great flight from the Northeast corner of COMSAT which flirted with IS 270 in the Southwest corner but DT'ed in time!

#### TEN-CENT SCALE MASS LAUNCH OCTOBER 30

CONTESTANT	MODEL	PLACE
Allan Schanzle	Arado	1
Chad Graham	Spartan	2
Doug Buchanan	Miller Racer	3

Not much of turnout but still fun for all present. Mike Graham's young nephew Chad Robert proxy flew for Mike; perhaps we have a new Maxecuter coming along.

---

---

## SAM HALL OF FAME

---

---

On Wednesday, September 14, 1994 in Muncie, Indiana our own Bill Winter was honored by the Society of Antique Modelers and inducted into their HALL OF FAME. Thus he joins many other illustrious modelers and industry greats such as Dick Korda, Maxwell Bassett, Chet Lanzo, Irwin Ohlsson, Frank Zaic, Frank Ehling, Earl Stahl, and Henry Struck to name just a few. The SAM HALL OF FAME was instituted in 1989 and now has 60 members.

Bill is a "man for all seasons" and has literally done it all: designed and flew every type of aircraft model except perhaps indoor models and helicopters; edit and publish more articles, magazines and books than anyone else in the field; and most of all has been and continues to be an inspiration for all the model aircraft community. Bill is 80plus years young and continues to design, build and fly. It is impossible to single out a significant accomplishment of Bill's; suffice to say they have all been significant to this hobby, and he continues as our mentor to this day. He is truly the doyen of the aircraft modellers! The honor is long overdue.

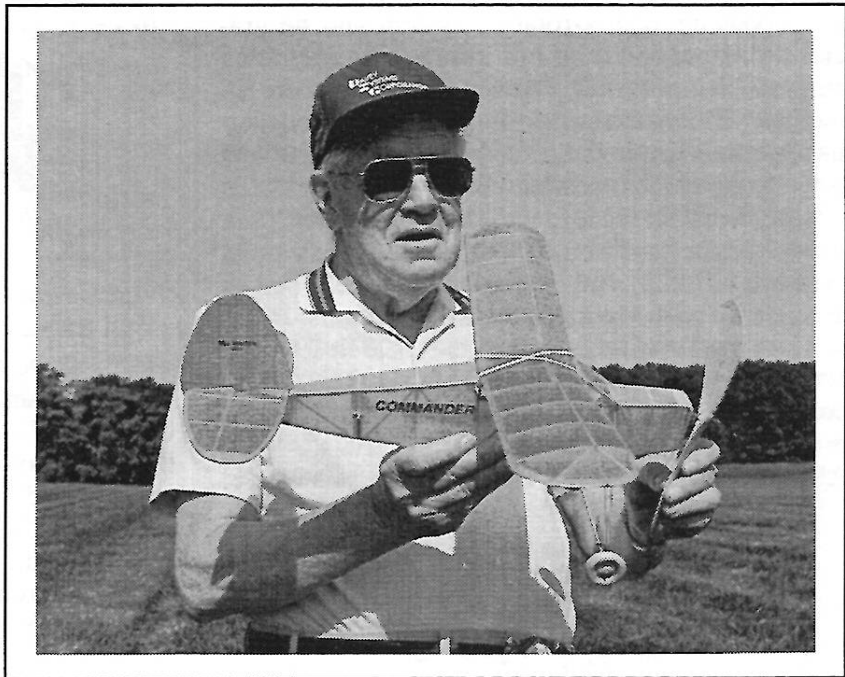

---

---

## PATUXENT RIVER INDOOR CONTEST

---

---

It has been a year's wait since our last fun fly at Pax but that did not hamper the spirits of all the attendees at the November '94 contest. Twenty-two happy modelers flew in at least one event and a number of other participants joined us to fly and just have a good time. Look for the results elsewhere in this issue of MAXFAX. Walt Eggert journeyed from Philadelphia just to watch and renew old friendships. He and Don Srull, another non-flyer, were enlisted to be our scale judges; and Allan Schanzle went into action and ran most of the MASS LAUNCH events. Bill Ceresa provided all the great art-work that decorated the many trophies and buttons awarded to the contestants. We welcomed David Aronstein, a new MAXECUTER, and he proceeded to fly a 159 second flight with his COCONUT Miles M.18 which we believe is a new max for this event at Pax. He also demonstrated his Panther jet with a ducted propeller

which was fascinating to watch with its snail-like flight. We continually owe a debt of gratitude to both Claude Powell and Bill Powell for making these Pax River events happen. Without them we would be looking for another indoor contest site. The attendees donated a total of \$110 for Navy Relief in appreciation of their efforts and the Navy's allowing our use of the Rotary Wing facility.

One new event was added at this contest. Claude had suggested the ELECTRIC BOGUS SCALE BOSTONIAN and it proved to be fun for the participants. The ROG takeoffs were very realistic and added a new dimension to our flying. We hope more attendees try it at our next Pax indoor contest which is tentatively scheduled for March 1995. It is not too much of a chore to convert a BOGUS SCALE BOSTONIAN to electric or to scratch-build one. Try it; you will like it!

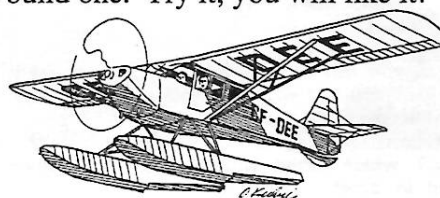

**PATUXENT RIVER CONTEST RESULTS NOVEMBER 5, 1994**

FAC RUBBER SCALE (9 ENTERED - 7 FLEW)						
CONTESTANT	MODEL	STATIC	BONUS	FLIGHT	TOTAL	PLACE
Tom Hallman	MartinsydeS.1	57	15	67	135.5	1
Dave Rees	Citabria	57	0	103	135.25	2
Frank Rowsome	J-3 Cub	53	0	84	125	3
Tom Hallman	Loose Racer	60	5	72	131	-
Steve Hales	Vagabond	49	0	66	112	-
John Houck	Gotha 147-B	49	15	43	107	-
Bill Bell	Bellanca C.F.	57	0	15	72	-

COCONUT (8 ENTERED - 3 FLEW)						
CONTESTANT	MODEL	STATIC	BONUS	FLIGHT	TOTAL	PLACE
David Aronstein	Miles M.18	15	10	157	182	1
Dave Rees	Citabria	28	0	103	131	2
Steve Hales	Vagabond	21	0	100	121	3

POWER SCALE (4 ENTERED - 1 FLEW)						
CONTESTANT	MODEL	STATIC	BONUS	FLIGHT	TOTAL	PLACE
Terry Pittman	Farman CartePost	52	3	67	117	1

OLD TIME KIT SCALE MASS LAUNCH			
CONTESTANT	MODEL	ROUND ELIM.	PLACE
John Houck	Mureaux C-1	-	1
Paul Spreiregen	Puss Moth	4	2
Allan Schanzle	Arado	3	3
Rich Gillis	Harlow PJC-2	2	-
Mike Moskow	Puss Moth	2	-
Doug Buchanan	Miller Racer	1	-
Stew Meyers	Chester Racer	1	-

WWI MASS LAUNCH			
CONTESTANT	MODEL	ROUND ELIM.	PLACE
Stew Meyers	Fokker D-7	-	1
John Houck	Junkers J-1	3	2
Dave Rees	MartinsydeS.1	2	3
Bill Bell	Fokker D-7	1	-
Tom Hallman	MartinsydeS.1	1	-

NAVY SCALE MASS LAUNCH			
CONTESTANT	MODEL	ROUND ELIM.	PLACE
Dan Driscoll	Bristol Scout	-	1
John Houck	XF2L-1	3	2
Frank Rowsome	F6F	3	3
Doug Buchanan	Martin MO-1	2	-
Bill Bell	Boeing F4B-4	1	-
Tom Hallman	Ohka "Baka"	1	-

PEANUT SCALE MASS LAUNCH (2 HEATS)			
CONTESTANT	MODEL	ROUND ELIM.	PLACE
Dan Driscoll	Ord-Hume OH-7	-	1
Frank Rowsome	J-3 Cub	5	2
Tom Hallman	Mr. Smoothie	4	3
Steve Hales	Babe Jodel	3	-
Rich Gillis	Nesmith Cougar	2	-
Bill Powell	Tailwind	2	-
Dave Rees	Contestor	1	-
Doug Buchanan	Firecracker	1	-
Terry Pittman	Jodel	1	-
Paul Spreiregen	Andreason	1	-

GOLDEN AGE MASS LAUNCH (3 HEATS)			
CONTESTANT	MODEL	ROUND ELIM.	PLACE
Dave Rees	Aristocrat	-	1
David Aronstein	Mess. M-20	5	2
Bud Carson	Farman	4	3
Rich Gillis	Cessna Airmaster	3	-
Tom Hallman	Loose Racer	3	-
Frank Rowsome	Miles Sparrowhawk2	-	-
Terry Pittman	Farman 190	2	-
Bill Bell	Monocoupe	2	-
Doug Buchanan	Farman 400	1	-
John Houck	Rearwin Speedster	1	-
John Lewars	Aeronca Champion	1	-
Dan Driscoll	Funk	1	-
Pat Daily	Avia BH7a	1	-
Paul Spreiregen	Fairchild	1	-
Mike Moskow	DGA	1	-

COCONUT MASS LAUNCH (7 ENTERED - 3 FLEW)			
CONTESTANT	MODEL	ROUND ELIM.	PLACE
David Aronstein	Miles M.18	-	1
Dave Rees	Citabria	1	2
Steve Hales	Vagabond	1	3

CONSOLATION MASS LAUNCH (10 ENTERED - 6 FLEW)			
CONTESTANT	MODEL	ROUND ELIM.	PLACE
Bud Carson	Farman	-	1
Tom Hallman	Mr. Smoothie	3	2
Dave Rees	MartinsydeS.1	3	3
John Houck	Junkers J-1	2	-
Frank Rowsome	J-3 Cub	2	-
Paul Spreiregen	Puss Moth	1	-

NO-CAL MASS LAUNCH			
CONTESTANT	MODEL	ROUND ELIM.	PLACE
Bud Carson	Cessna Racer	-	1
Rich Gillis	Goosling	2	2
Bill Powell	Porter	2	3
Tom Hallman	Hawker Typhoon	1	-

14 GRAM BOSTONIAN (9 ENTERED - 7 FLEW)			
CONTESTANT	MODEL	FLIGHT	PLACE
Terry Pittman	Oiseau Fou	105	1
Pat Daily	Aristocrat	98	2
John Houck	Boston Found	94	3
Doug Buchanan	Found	93	-
Dan Driscoll	Robin	90	-
John Lewars	Bean Box	75	-
Rich Gillis	Citabria	53	-

7 GRAM NO-CAL			
CONTESTANT	MODEL	FLIGHT	PLACE
Bud Carson	Cessna Racer	165	1
Rich Gillis	Goosling	119	2
Bill Powell	Porter	115	3
Tom Hallman	Hawker Typhoon	54	-

ELECTRIC BOGUS SCALE BOSTONIAN (5 ENTERED - 4 FLEW)			
CONTESTANT	MODEL	FLIGHT	PLACE
Tom Schmitt	Wong Way Robin	75	1
Claude Powell	Bostabria	67	2
John Lewars	Wong Way Robin	32	3
Frank Rowsome	Prairie Watt	5	-

LIMITED PENNYPLANE			
CONTESTANT	MODEL	FLIGHT	PLACE
Randy Kleinert	?????	426/401*	1
Frank Rowsome	Blue Penny	428/225*	2
Paul Spreiregen	Cezar Chavez	253	3

\* Tie was decided by the second highest flight.

GRAND CHAMPION RESULTS*					
CONTESTANT	1sts	2nds	3rds	POINTS*	PLACE
Dave Rees	1	3	1	76	1
Bud Carson	3	-	1	54	2
John Houck	1	2	1	50	3
Dan Driscoll	2	-	-	48	-
David Aronstein	2	1	-	48	-
Tom Hallman	1	1	1	43	-

\* Points were determined by multiplying number of each event entries by the contestant's event place points (1st-3pts; 2nd-2pts; 3rd-1pt) and summing for the total points.

**Don't be left shirtless for the next big event!**

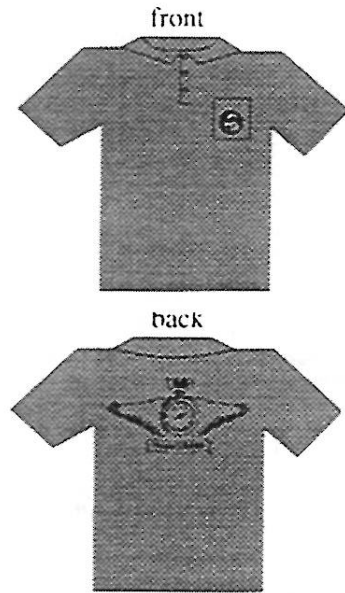

DC Maxes  
Polo Shirt



*Just One  
Jackson!*

Color: Light Blue (with logo printed in dark blue)  
Style: Jersey Knit Polo in 100% cotton with front pocket  
Sizes: M, L, XL

Order now before they become extinct.  
Place order with Stew Meyers at 301-365-1749

**PHOTO PAGE**

1. Our featured plan for this issue is Paul Boyanowski's magnificent Short Empire Boat. Photo courtesy of Pat Daily.  
1994 COMSAT FUN FLY
2. Marie Rees bested 14 other GOLDEN AGE flyers at this past summer's FUN FLY with her Vega, a great flyer.
3. Pat Daily built another Wildcat for COMSAT and achieved a well deserved second place in FAC RUBBER SCALE.
4. Tom Hallman flew this BAKA in the WWII event.  
1994 NORTH CAROLINA SEAPLANE SPLASH AND KUDZU CONTEST
5. Frank Rowsome illustrates what terrible tan can do to a four pound balsa fuselage; blew in half when fully wound!
6. A nifty little twin rubber seaplane by Don Srull was a great flyer off the water; R.O.W.s without hiccups.
7. Chuck Wojtkiewicz launching his Curtiss seaplane; this year sans loops.
8. A Farman by Terry Pittman gave him trimming fits. Don't give up Terry.

**"DIAMONDS (NUTS) ARE FOREVER"!**

There is no stopping Bill Hannan; he is rapidly converting all of us to nut devourers, "Peanuts & Pistachios" that is! Peanuts & Pistachios VI is his latest and as usual it has everything; plans, great photos and touching memories of Walt Mooney, the "best of the best". An interesting anecdote "Use Your Best" by Jim Alaback aroused a nerve in this reporter. It is a trap that I fall into often. For those male modelers that need a little pulchritude to round out their model aviation reading don't overlook the photos of Doreen Virtue and the Toner sisters. And then just think "Peanuts & Pistachios VI" is not fattening! What more can one ask for? For your copy contact Hannan's Runway, Box 210, Magalia, California, 95954 ; phone (916) 873-6421. The price is only \$9.95 plus \$2.00 postage. Ask for Bill and Joan's catalog; it is full of other goodies with most of Bill's books still available. The more of us that buy, the more of these gems that will flow from the talented pen of Bill.

**NEW! PEANUTS & PISTACHIOS VI**

COMPILED BY BILL HANNAN

New from Hannan's Runway, Volume 6 in our popular Peanuts & Pistachios series accentuates vintage aircraft. Featured are model construction plans, documentation, articles and a world-wide selection of fine photographs to inspire greater excellence in your own modeling!

**HIGHLIGHTS OF VOLUME SIX**

**MODEL CONSTRUCTION PLANS:**

- 1909 Demoselle, by the late Walt Mooney (USA)
- 1912 Sommer Monoplane, by J.F. Fragoli (France)
- 1931 AVRO Cadet, by Kim McDonough (England)
- 1939 Waco SRE, by Walt Mooney (USA)

**DOCUMENTATION DRAWINGS:**

- 1909 Demoselle, by the late Wally Benter (Canada)
- 1910 Demoselle, from a ZFM magazine (Germany)
- 1911 Voisina Hydro Canard I, by Ramo Sabel (Germany)
- 1911 Nieuport "double-tail", by Bill Hannan (USA)
- 1931 AVRO Cadet, by Kim McDonough (England)
- 1938 Mew Gull, by Harry Robinson (England)
- 1939 Waco SRE, by Harry Pack (USA)

**ARTICLES:**

- Walt Mooney Remembered
- Mooney's Modeling Methods } compiled by Bill Hannan
- Delightful Demoselles
- Use Your Best! By Jim Alaback
- Feedback from our readers (extracts from letters)

**PHOTO ESSAYS:**

- Peanuts & Pistachios People • The Peanut Gallery
- Symphony in Structures • The Pistachio Presentation

\$9.95 plus \$2 postage and packing (book rate)

or \$2.50 for First Class Mail (faster!)

Note: 2 or 3 copies can travel for the same price as 1.



Format: 8 1/2" x 11", 2 color cover, 28 pages, 58 photos, 4 model plans, 7 documentation drawings, and cartoons, sketches and whatever, printed on superior quality stock for long life.



Mew Gull



AVRO Cadet



Hannan's  
RUNWAY  
Box 210  
Magalia  
CA 95954 USA  
(916) 873-6421



Still available: Peanuts & Pistachios Volume 1: \$6.95  
Peanuts & Pistachios Volume 2: \$7.95  
Peanuts & Pistachios Volume 3: \$7.95  
Peanuts & Pistachios Volume 4: \$7.95  
Peanuts & Pistachios Volume 5: \$7.95  
Plans & Views Volume 1: \$9.95  
Stick & Tissue Volume 1: \$9.95  
Stick & Tissue Volume 2: \$9.95  
Stick & Tissue Volume 3: \$9.95

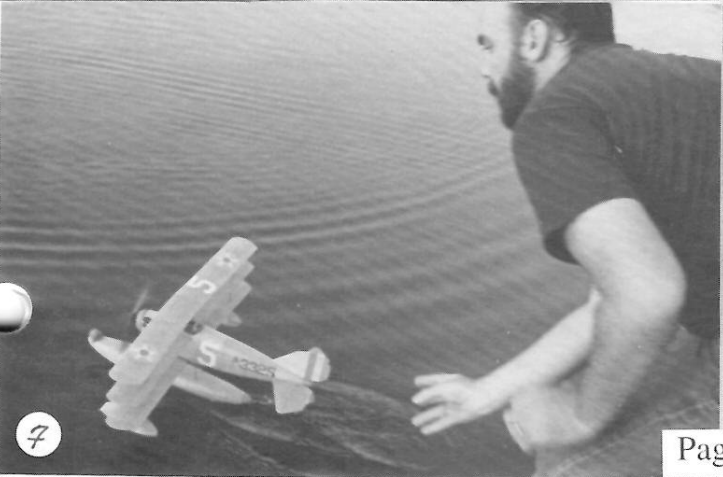
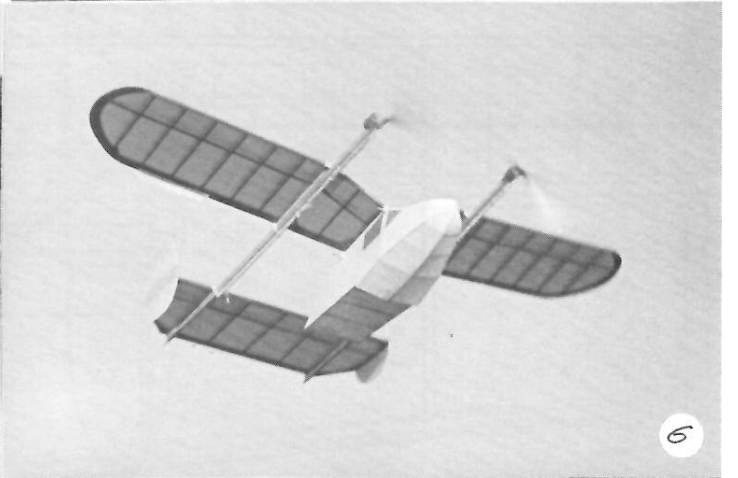

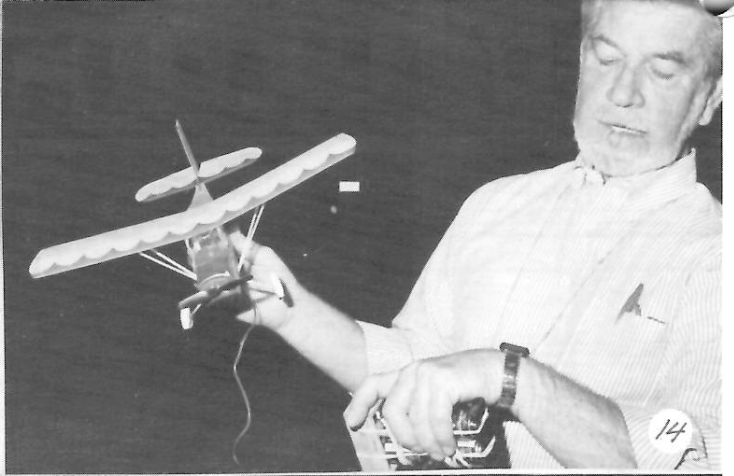
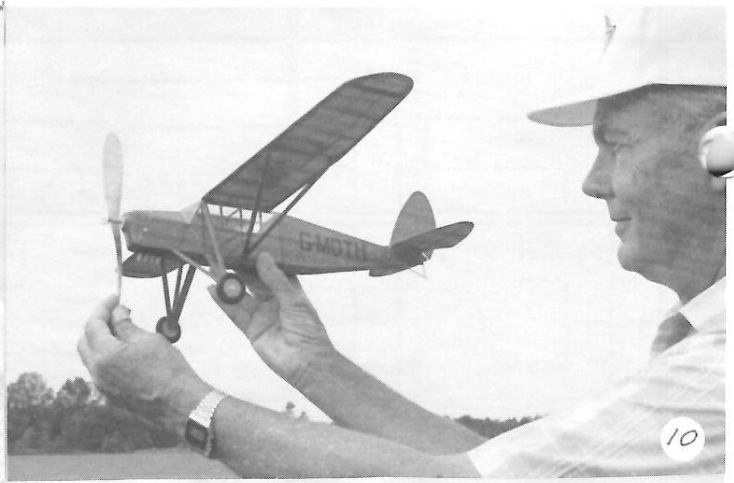



**PHOTO PAGE**

**AT RAEFORD**

- 9. Bert Phillips came with a brand new Monocoupe.
- 10. A pretty Puss Moth by David McLellon from Norfolk.
- 11. David Franks likes the big ones; look at this great AD.
- 12. Allan Schanzle's Arado was built from the Comet plan in the Sept/Oct '94 MAXFAX. It is a good flyer.

**PAX RIVER INDOOR CONTEST  
NOVEMBER 1994**

- 13. JOHN HOUCK always shows up with at least one distinctive aircraft; his Gotha 147B managed a respectable 43 seconds in FAC RUBBER SCALE..
- 14. Claude Powell flew his Bostabria in the ELECTRIC BOGUS SCALE BOSTONIAN event. Hope more of these show next time; the takeoffs and flights are very realistic.
- 15. A new member David Aronstein put on a demonstration of light weight flyers with his aircraft; seen here with his GOLDEN AGE entry. a Messerschmitt M20.
- 16. Dan Driscoll hams it up after winning PEANUT SCALE MASS LAUNCH with his Ord Hume OH7 finished the evening before the contest. We are all happy he does not have more building time; just kidding Dan!

**THE GOLDEN HIND**

**SHORT S.26 G-CLASS FLYING BOAT  
Full-Size Plan Feature**

We could not resist asking Paul Boyanowski for a set of his plans for "The Golden Hind" after seeing it in action at Geneseo. It should make a dandy electric model with two motors; or four motors with some plan enlargement. Of course those of you out there looking for real bonus points should try four rubber motors! With a little arm twisting Paul graciously sent his plans and some building information. Also with a little more arm twisting our local ace plans manipulator Bill Ceresa rearranged the drawing to fit on three 11 by 17 sheets.

Now for some info from Paul;  
"I don't think the nacelles would have to be

fudged nearly as much on an electric version. I know a lot of modelers don't like the rubber sticking out the back of the nacelle, but the setup worked real well. Recently I got a chance to complete trimming the model and it was a pleasant surprise. Like most high wings it was predictable to trim changes. Very little was required to get the boat flying. I added 4-5 degrees downthrust on both motors and nose ballast. All the wood used was in the 4-6 pound range. I believe the 3/16 sheet used to fabricate the leading and trailing edges was in the 8 pound range. I built the wing thick and hollow for rubber motor clearance. Initial concerns over structural integrity have been put to rest. The sheeted leading edge provides ample stiffness and strength."

Good reference material concerning the Golden Hind may be found in the Putnam Book "Shorts Aircraft since 1900" by CH Barnes and also in "The Illustrated Encyclopedia of Propeller Airliners" by Bill Gunston, an Exeter book.

**THE "DUCK"**

**Another Full-Size Cutie**

Louis Garami designed a gaggle of wonderful free-flight models for most of the great model mags of the 50's, 60's, and 70's. None was more novel or representative of his pure-fun designs than the "Duck" - a sport rubber-powered amphibian. It's a simple little ship, mostly of sheet balsa, and meant for knockaround flying off the pond out back or the empty field next door. If the wire bending required for that "retractable" landing gear looks too challenging, leave it off. These little guys land better on the COMSAT grass without a landing gear anyhow. Better yet, why not build a little Duck and join us at Dave Rees pond next year !

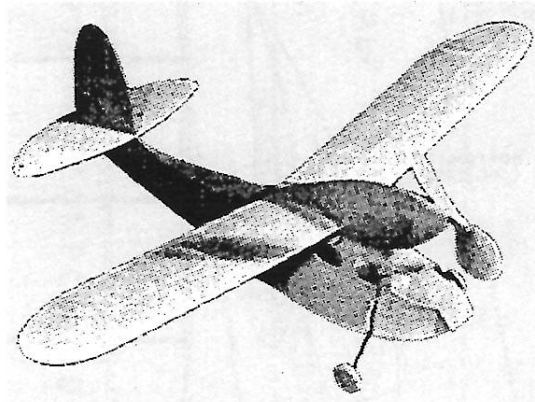

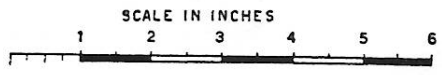
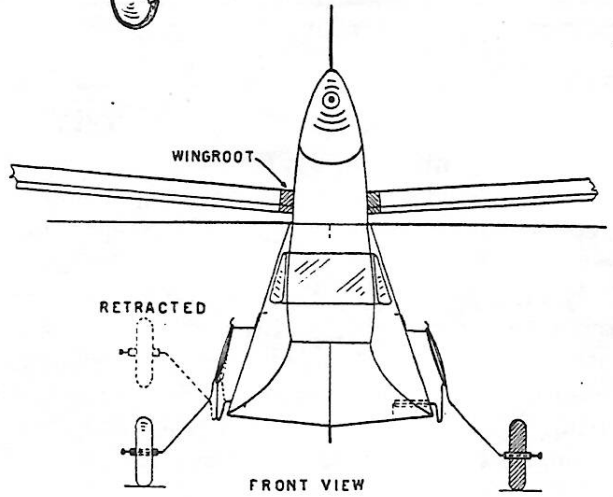
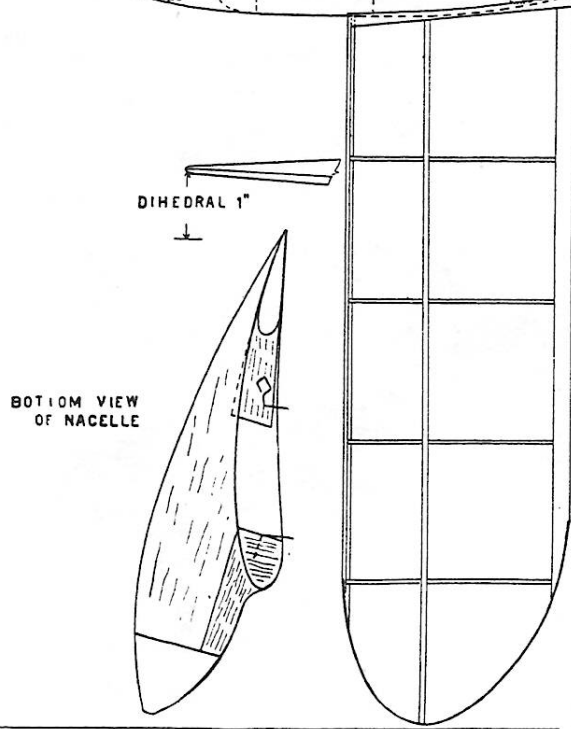
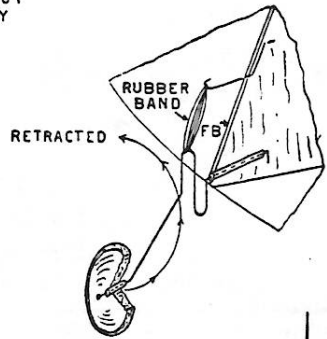
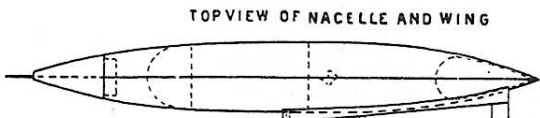
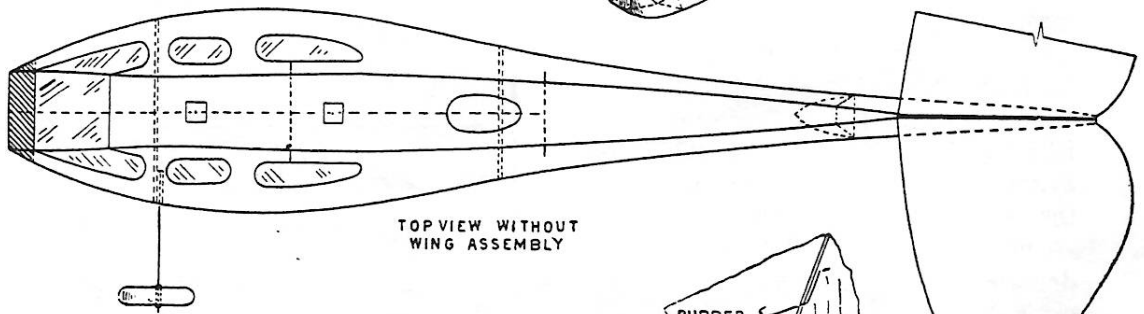
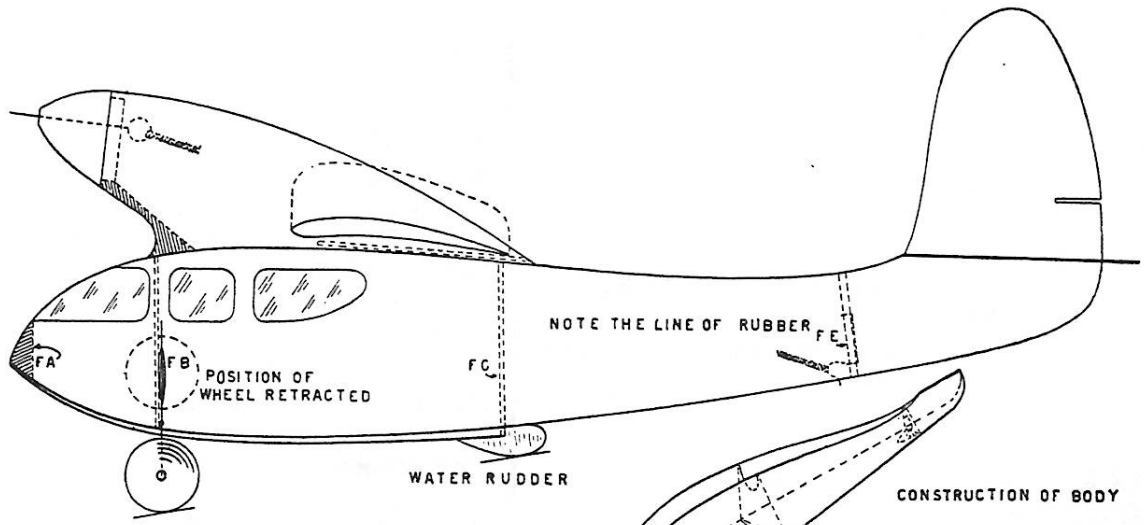

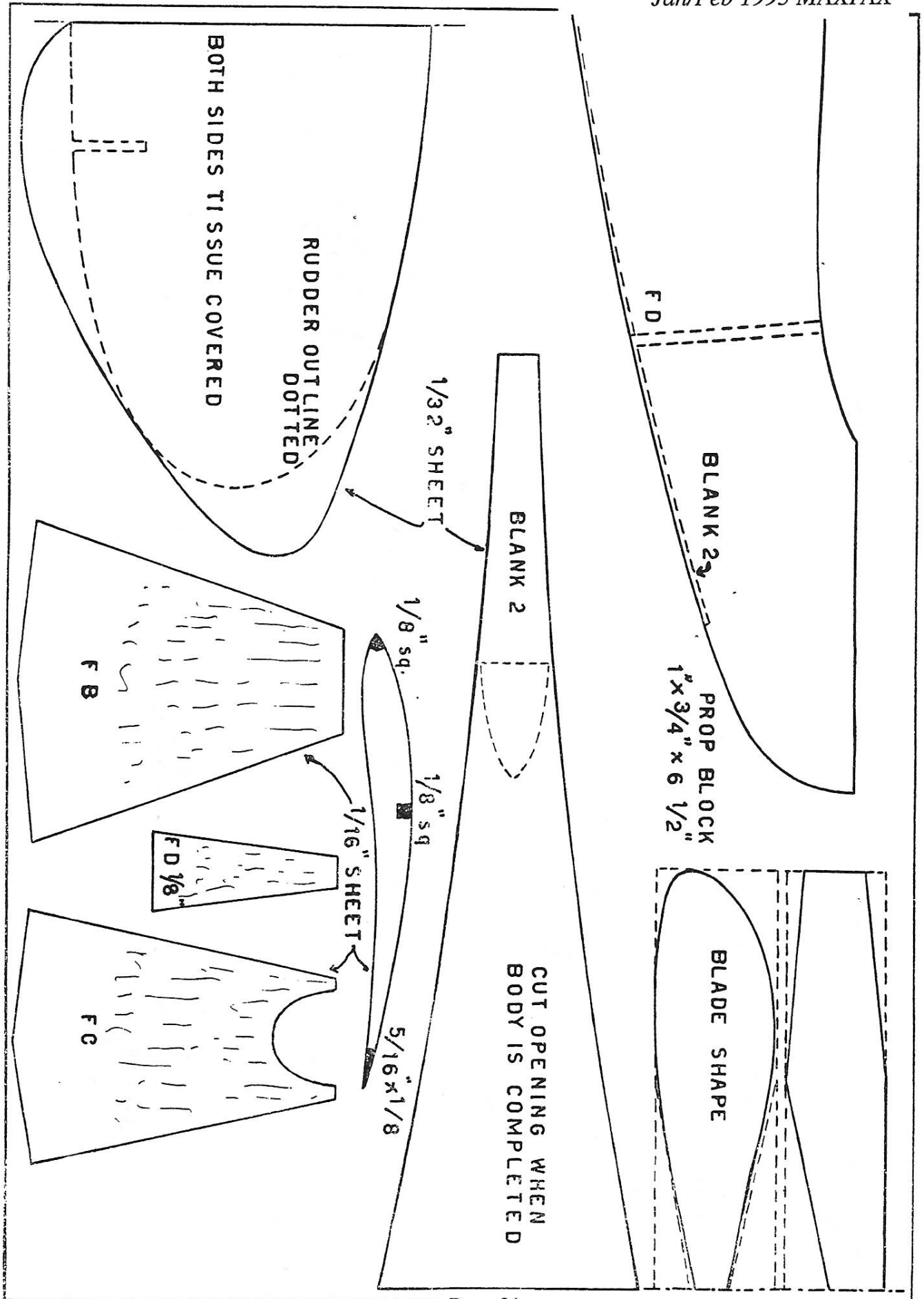

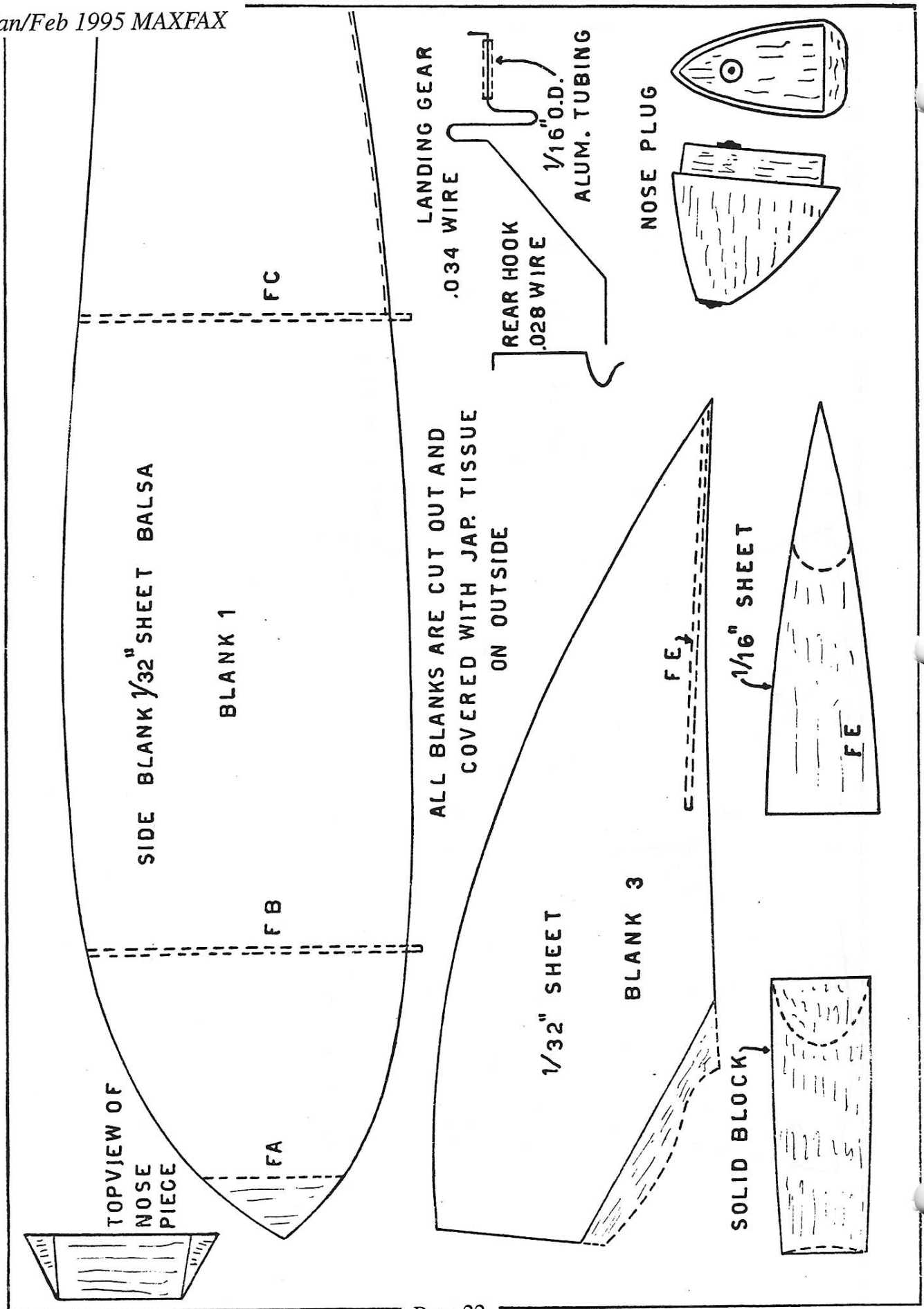

★ PAX RIVER INDOOR CONTEST ★

SATURDAY, MARCH ??, 1995 9:00 AM to 5:30 PM

(CONTEST DATE CONFIRMATION WILL BE IN THE MAR/APR MAX-FAX)

ROTARY WING HANGAR-BUILDING 111 NAS/NATC PATUXENT RIVER-LEXINGTON PARK, MD

NO ENTRY FEE - DONATIONS TO NAVY RELIEF SOCIETY WELCOMED

MAJOR EVENTS (FAC Rules & Trophies awarded)

•MASS LAUNCHES

- 1.- OLD TIME SCALE \* 11:00 AM
- 2- WW-1 12:00 PM
- 3- NAVY SCALE 1:00 PM
- 4- PEANUT SCALE 2:00 PM
- 5- GOLDEN AGE 3:00 PM

•OTHER EVENTS

- 6. FAC RUBBER SCALE
- 7- COCONUT SCALE \*\*/\*\*
- 8- 14 GRAM BOSTONIAN\*\*/\*\*

SPECIAL EVENTS

- 1- FAC POWER (Electric & CO2)
- 2- 7 GRAM NO-CAL\*\*\*
- 3- NOVICE PENNYPLANE (AMA RULES)\*\*\*
- 4- MASS LAUNCH CONSOLATION EVENT  
- Flown About 4:30 PM \*\*\*\*
- 5- COCONUT MASS LAUNCH \*\*\*\*\*
- 6- NO-CAL MASS LAUNCH\*\*\*\*\*
- 7- ELECTRIC BOGUS SCALE  
BOSTONIAN\*\*/\*\*/\*\*\*\*\*

\* OLD TIME SCALE RULES - Built from any old time kit plan which was sold before December 31, 1942 with a 20 inch wingspan or less. Construction may be heavier but not lightened; nose block and rear motor attachment may be modified.

\*\* COCONUT RULES -All COCONUTS (and BOSTONIANS) must ROG for official times except for the special MASS LAUNCH event.

\*\*\* Single best flight time determines winner.

\*\*\*\* SECOND and THIRD place flyers from the 5 standard MASS launch events are eligible to enter this event but must use plane flown in those events.

\*\*\*\*\* These events will be flown about 3:30 and 4:00 PM.

\*\*\*\*\* HiLine MICRO-4 motor (or 2-cell rewind) with 2 cell 50 mah battery maximum .

•AIRCRAFT FOR SCALE JUDGING MUST BE TURNED IN BY 11:00 AM;

No Qualifying Flight is Required

•ONLY ONE MASS LAUNCH EVENT PER AIRCRAFT

•ALL FLIGHT TIMES MUST BE SUBMITTED BY 4:30 PM

•AWARDS - 5:15 TO 5:30 PM

CONTEST INFORMATION: CLAUDE POWELL (301) 872-4105, or TOM SCHMITT (301) 530-0327

IMPORTANT : PLEASE CONTACT CLAUDE POWELL AT LEAST ONE WEEK BEFORE CONTEST TO PROVIDE YOURS AND GUESTS NAMES FOR ENTRY TO BASE — IF YOU HAVE DONE SO IN THE PAST YOU DON'T HAVE TO THIS TIME. ALSO, NOTE THERE ARE NO CHAIRS OR TABLES AVAILABLE, SO BRING YOUR OWN !

SPONSORED BY: NAVAL AIR STATION/NAVAL AIR TEST CENTER, PATUXENT RIVER, MARYLAND AND ST. MARY'S COUNTY RECREATION AND PARKS

**LISTEN-UP !** Make sure you set aside this 14th of January to attend Pat Daily's annual bull session. The plan is similar to last year's successful outing. We will first meet at the Richmond International Airport (RIA) museum at 1 PM, then head over to Pat's house by 5 PM for a major showing and telling and lying session. The map below should get you there from anywhere.

Meet at the Virginia Air Museum at 1:00 PM.  
Regroup at Pat's house at 5 PM for craziness.



Pat's phone : (804) 330-0825  
3452 Lady Marion Ct.  
Richmond, VA

NOTE: It's about 95 miles from the south end of the D.C. beltway to the museum.

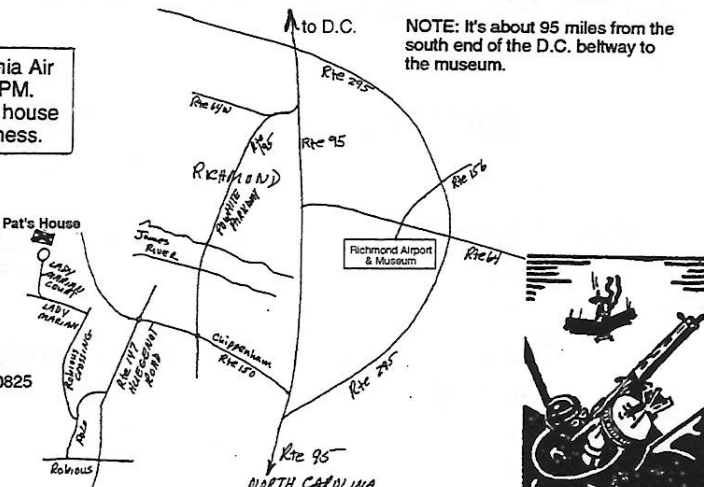

**ODDS AND ENDS**

We are certain that all of you sharp eyed readers out there have noticed the nifty line drawings of both model and full scale aircraft in the past several issues of MAX-FAX. If you examine them closely you will notice the artist's signature on each one. Otto Kuhni was kind enough to give us a number of these great sketches for use in the newsletter. You will be seeing more of them in future issues. **THANKS OTTO!**

We must give credit for the great Nov/Dec issue of MAX-FAX to its able editor Ray Rakow. He along with his two story tellers Hurst Bowers and Bert Phillips put together a newsletter that generates the travel urges in all of us. Ray screened and laid out all the photos which complimented the stories. Wish we all could have been there! Oh well, there is always next year. We do wish to point out that the Klemm L-33 drawing is the work of John Lewars not John Low as noted.

**NOTE: Your Dues Are Due**

<b>CLUB OFFICERS</b>	President	Terry Pittman 7863 Colonial Vil. Row Annandale, VA 22003
	Secretary	Bert Phillips 1709 Crofton Pky Crofton, MD 21114-2305
	Treasurer	Frank Rowsome 10904 Bellehaven Rd. Damascus, MD 20872



**MEETINGS** The D.C. Maxecuters hold meetings on the first Tuesday of every month at the College Park Airport, the oldest operating airport in the U.S.

**MEMBERSHIP** Dues for membership in the D.C. MAXECUTERS is \$15 per year for residents of the USA, Canada, and Mexico, and \$25 for all other countries. Your mailing label indicates the year and month of the last issue of your current membership. A red "X" in the box above is a reminder that your dues are due. Send a check, payable to the "D.C. MAXECUTERS", to the treasurer.

Opening in Bulkheads Typ.

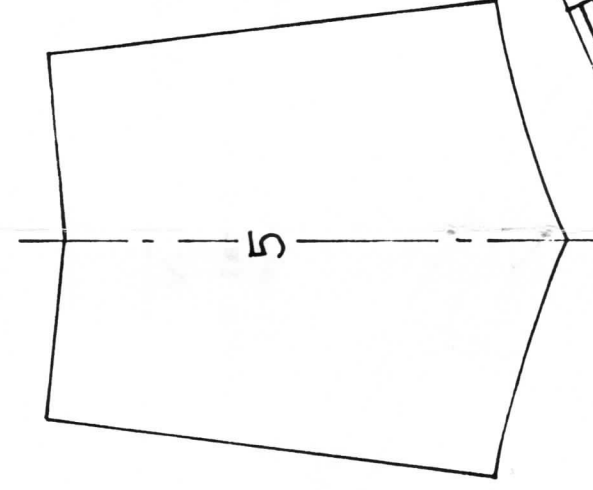
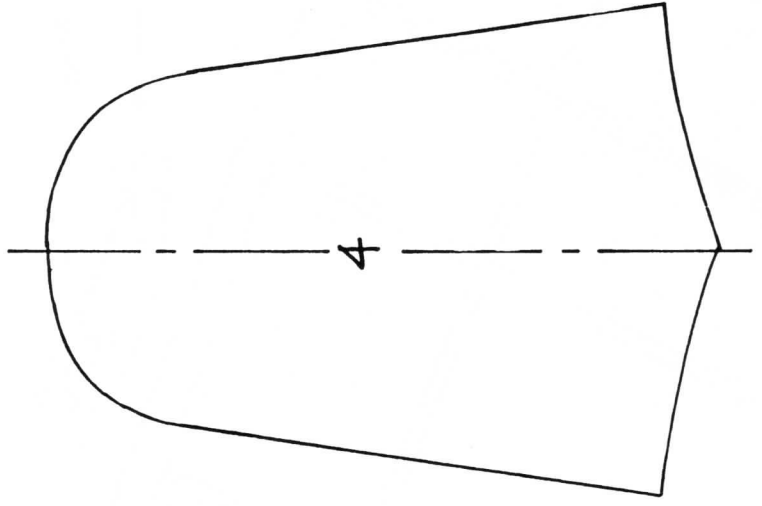
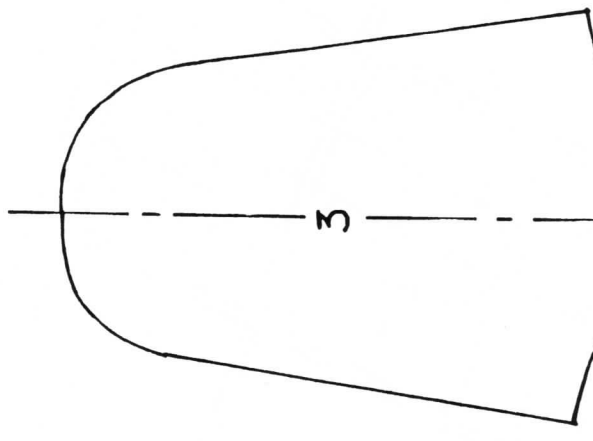
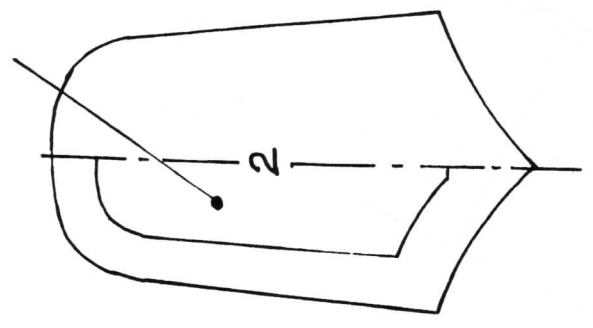

**SHORT S.26**  
by  
PAUL BOYANOWSKI

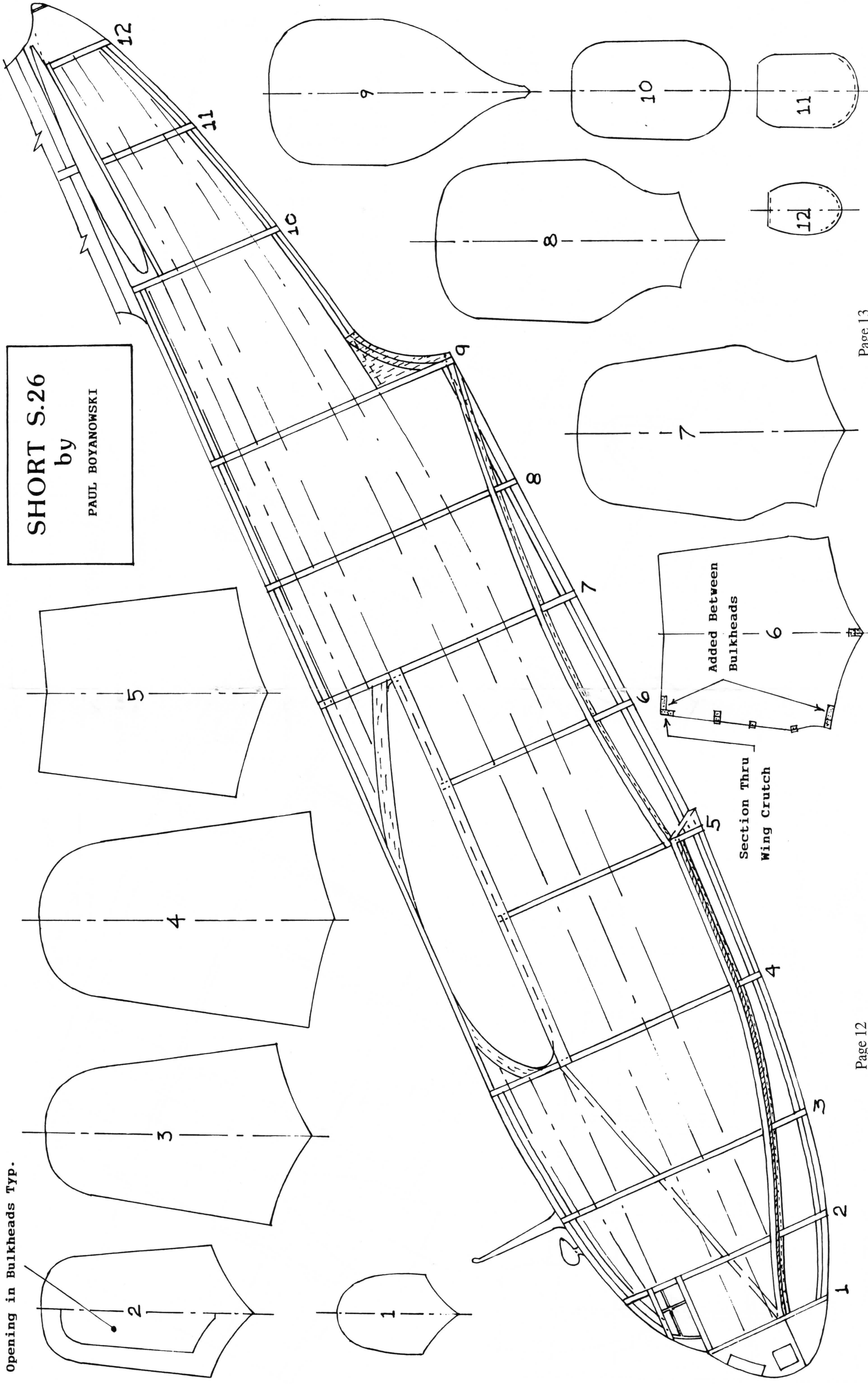
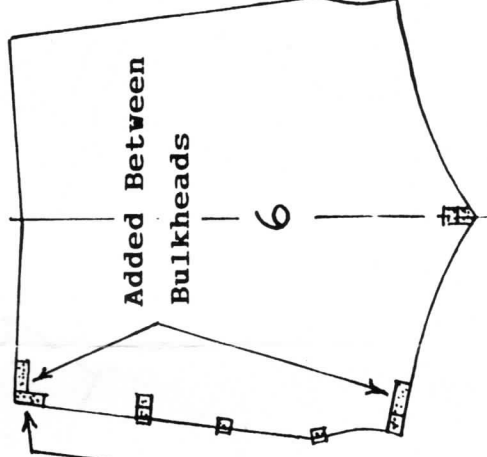
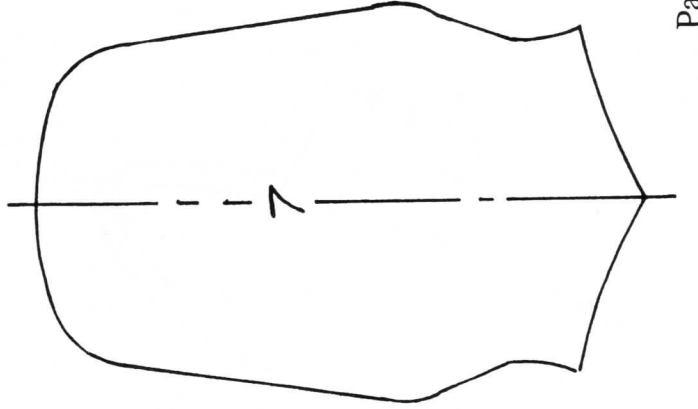
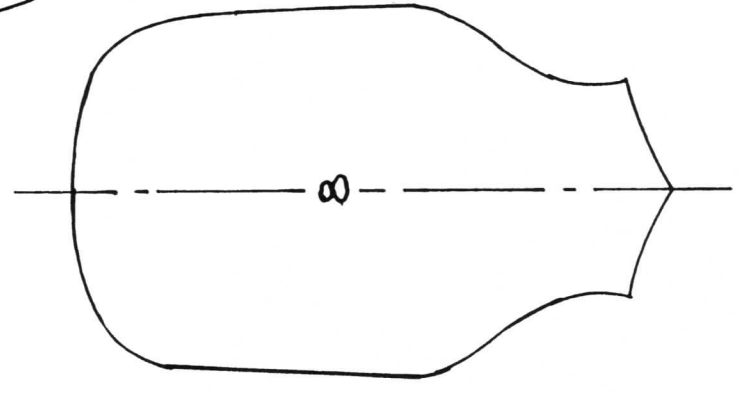
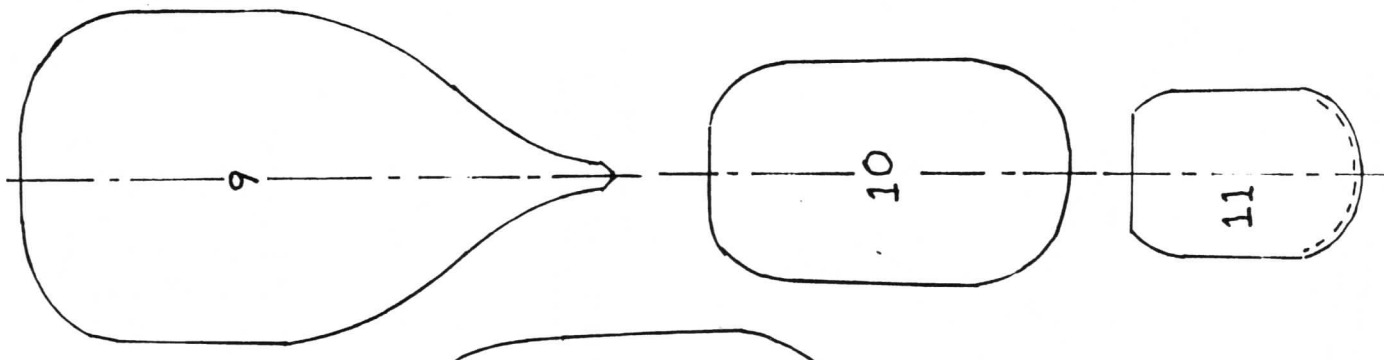
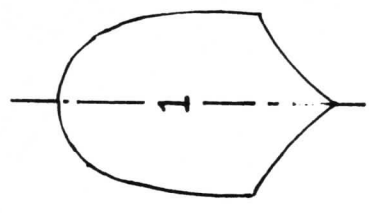

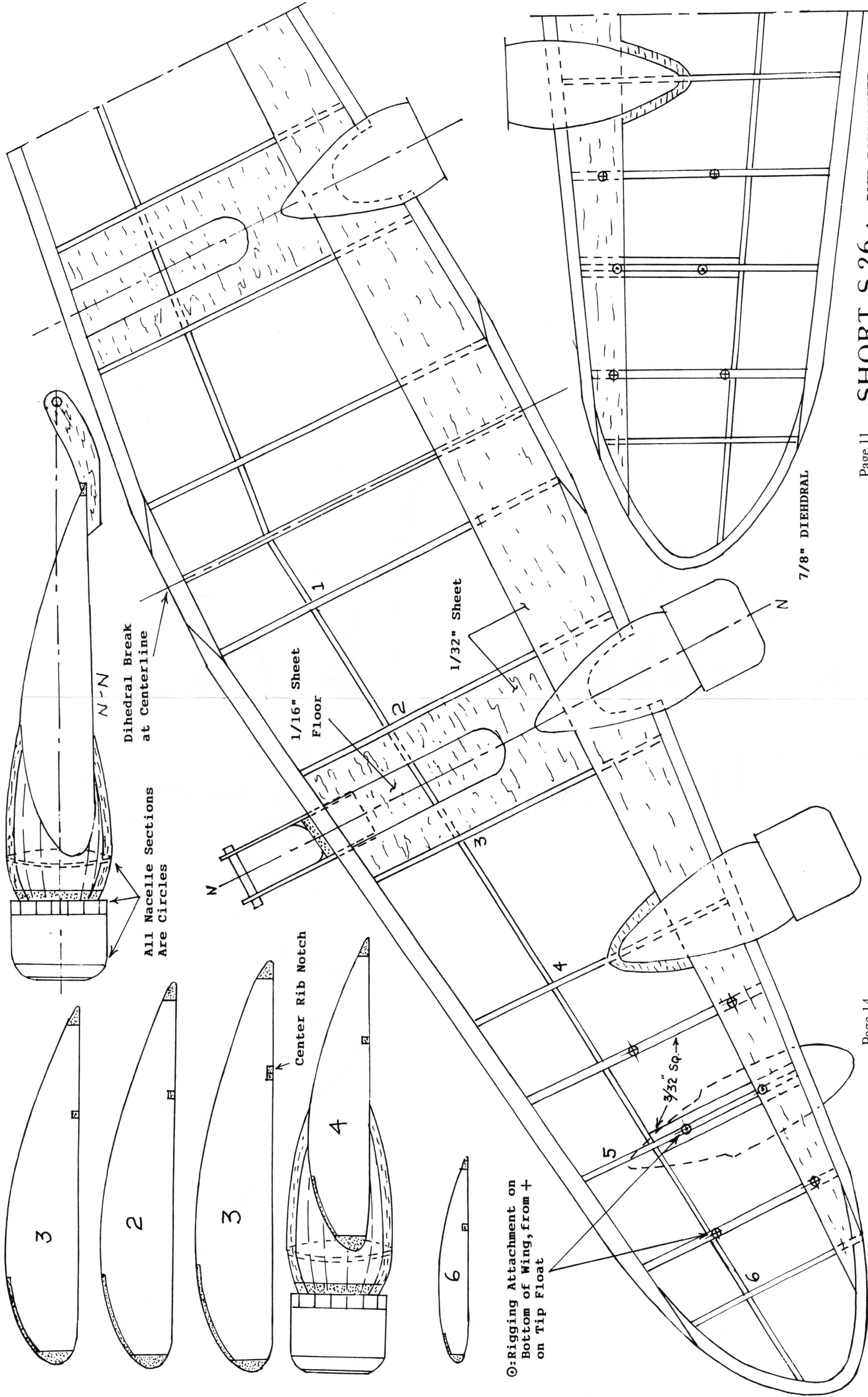

Dihedral Break at Centerline

All Macelle Sections Are Circles

1/16" Sheet Floor

1/32" Sheet

Center Rib Notch

○: Rigging Attachment on Bottom of Wing, from + on Tip Float

7/8" DIEHDRAL



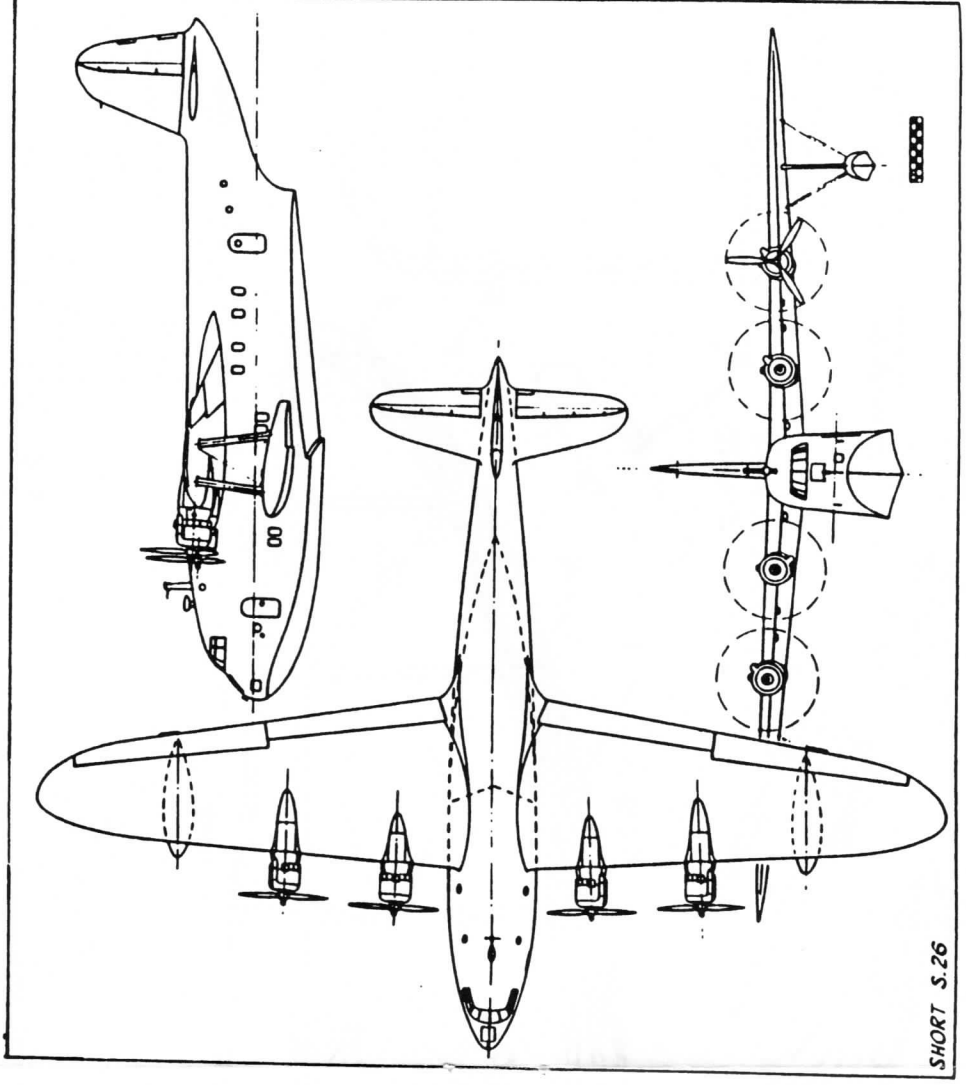
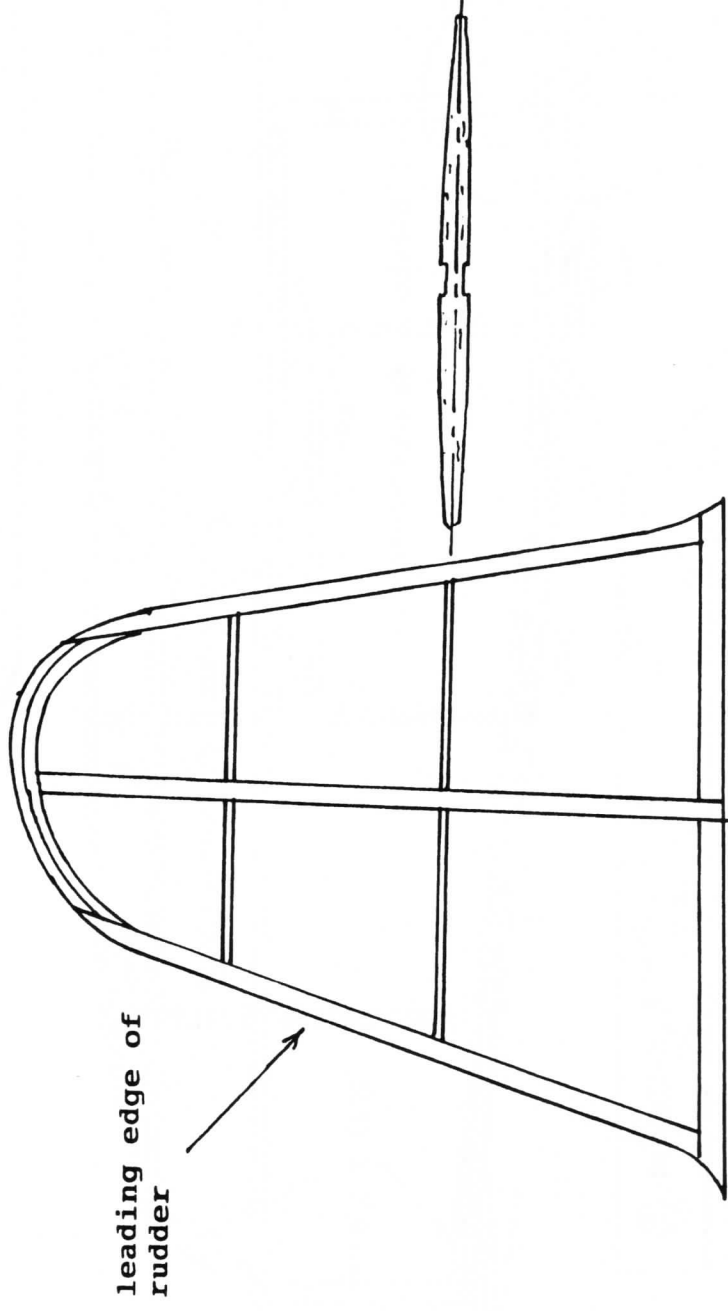
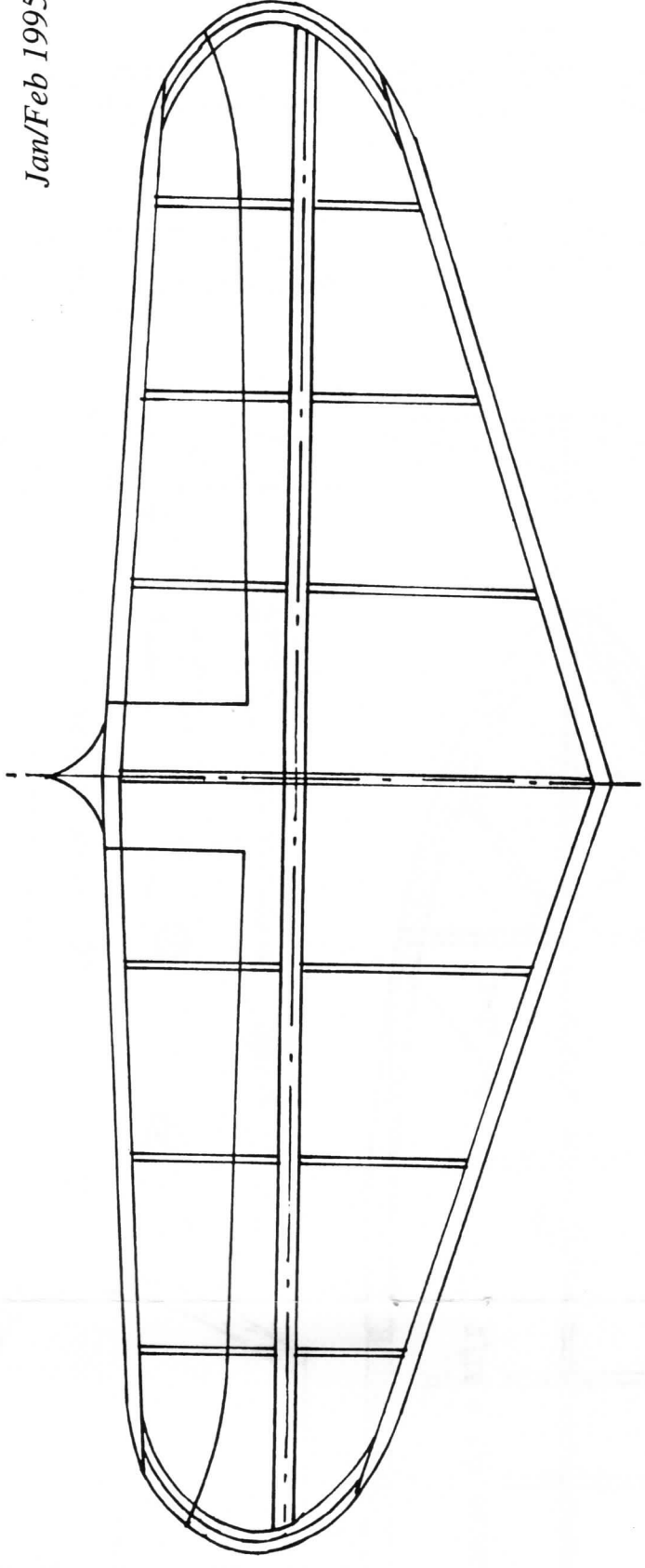
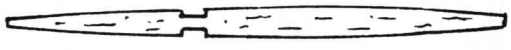
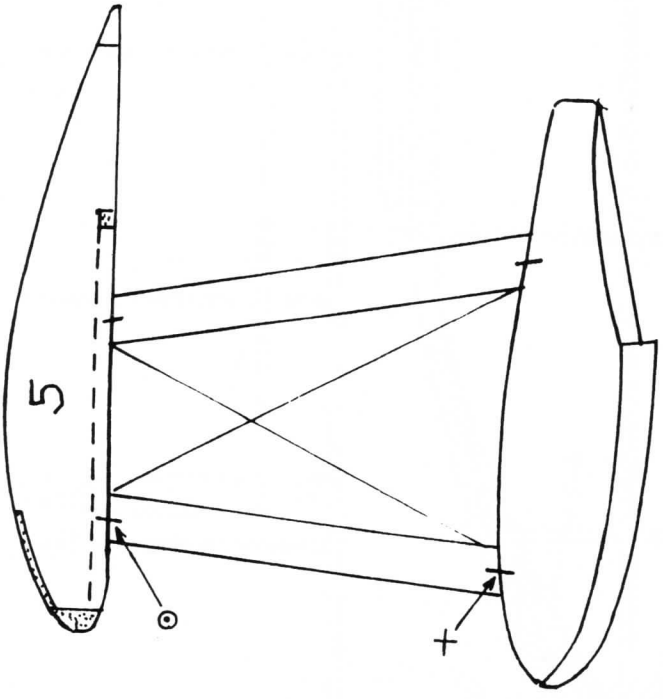

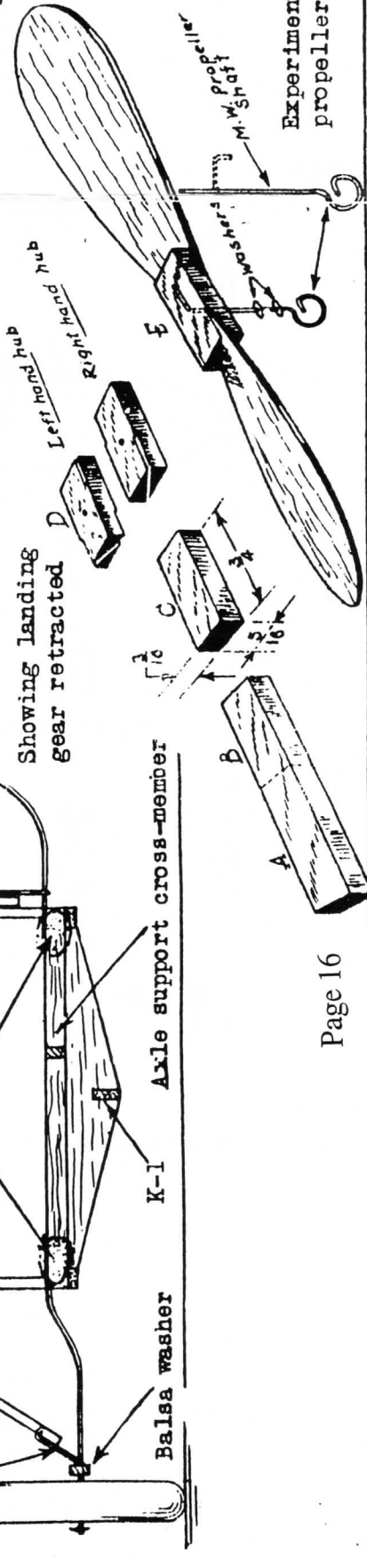
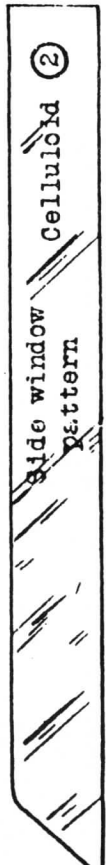
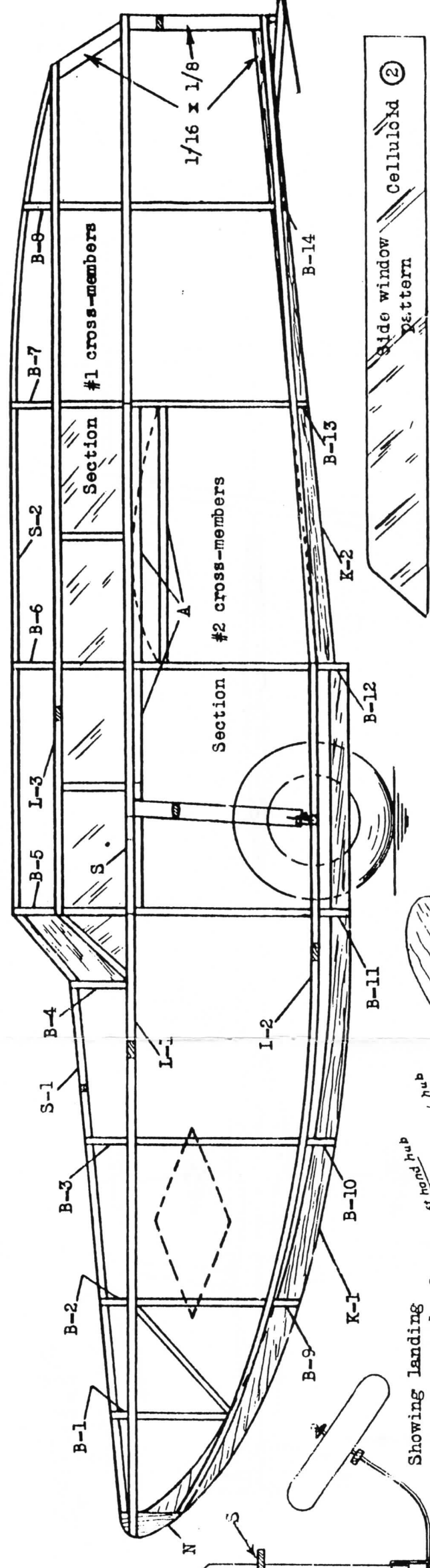
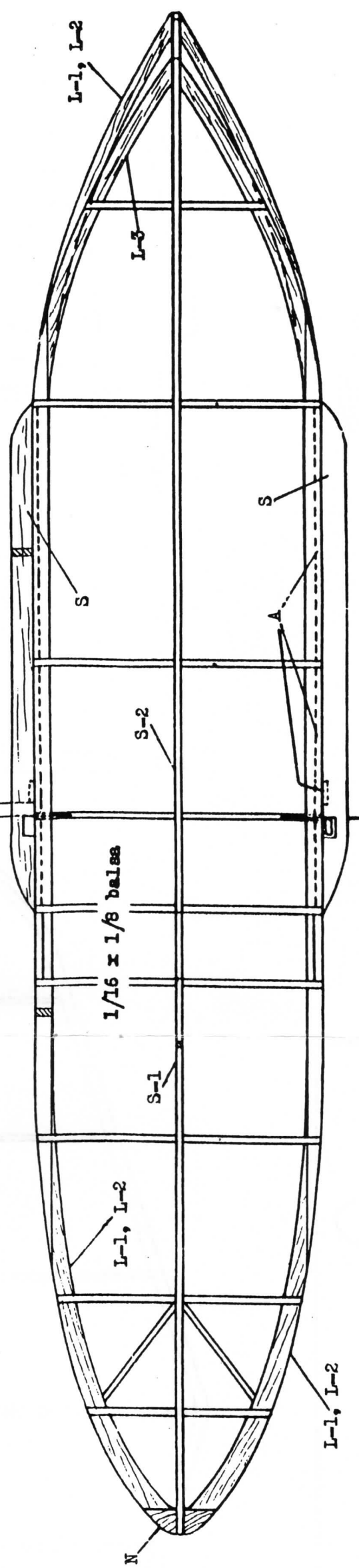
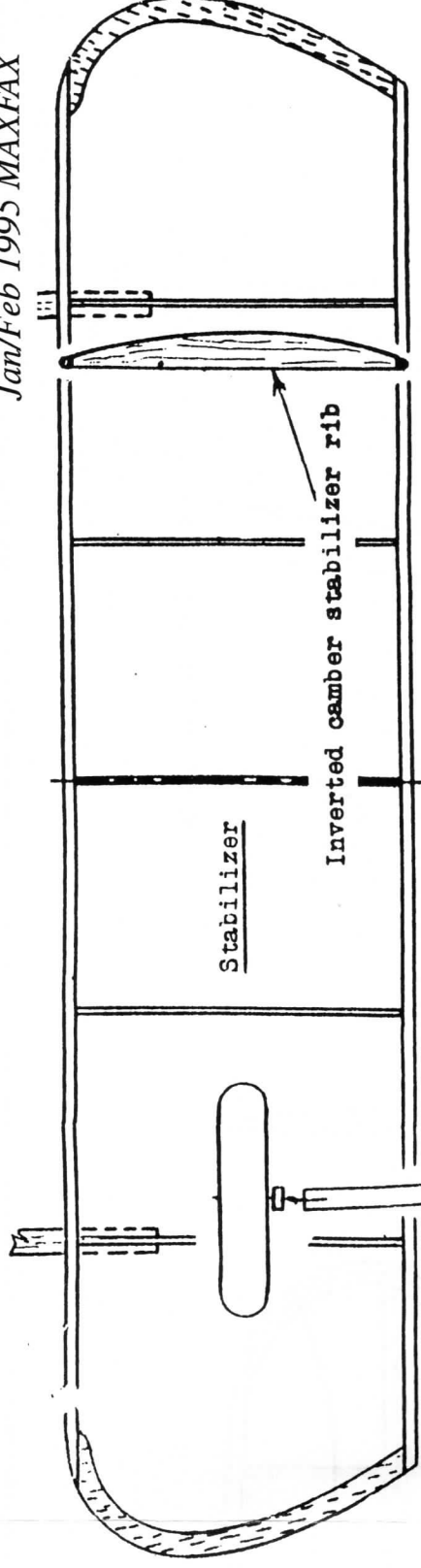
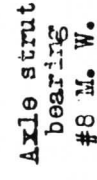
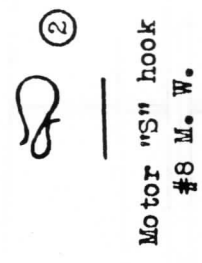
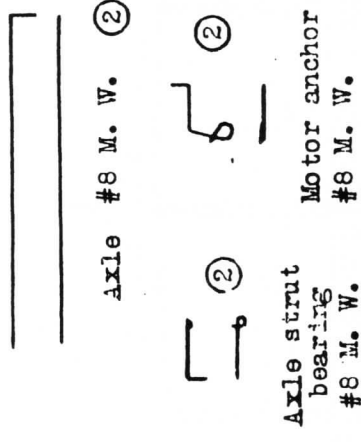
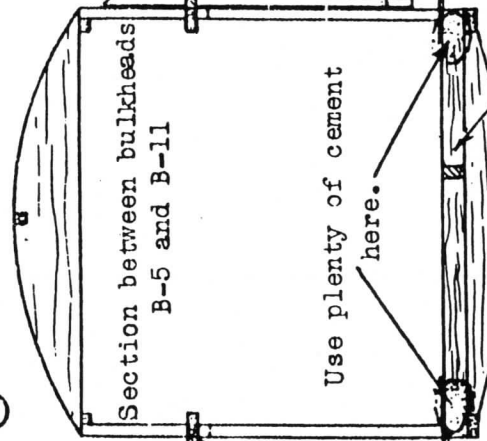
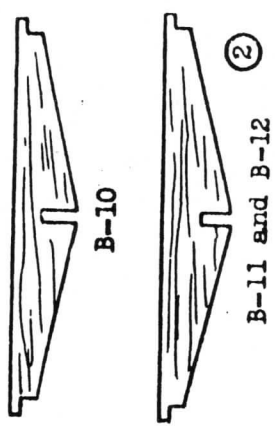
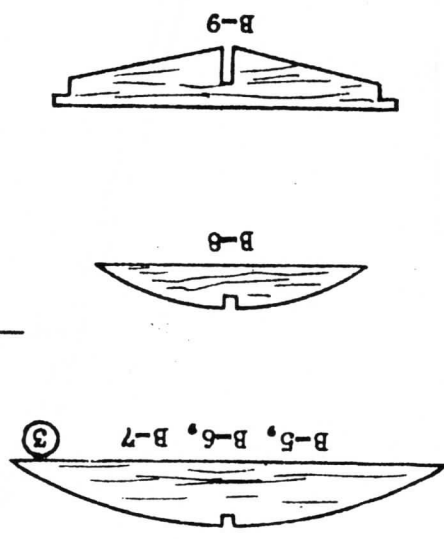
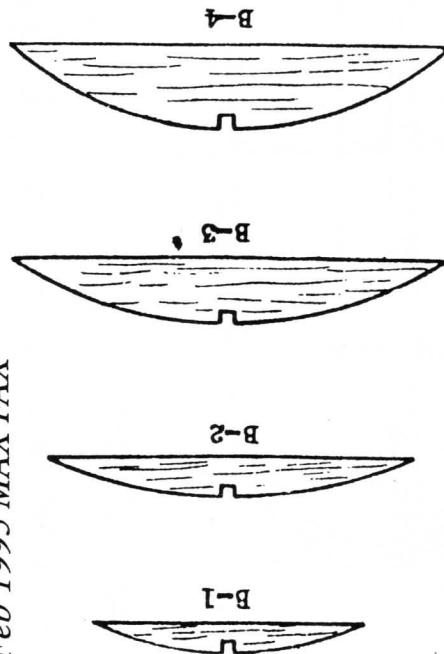

Copyright 1936 By CLEVELAND MODEL & SUPPLY COMPANY INC. CLEVELAND, OHIO, U.S.A.  
 INFRINGEMENTS BY COPYING, TRACING OR DUPLICATING ALL OR PART OF THESE DRAWINGS WILL BE SEVERELY PROSECUTED TO THE FULL EXTENT OF THE LAW.

A CLEVELAND-DESIGNED REP FLYING MODEL RX 5001

CLEVELAND AMPHIBION

THIS DESIGN INCORPORATES THE EXPERIENCE OF THIRTY CONCERN AS MODEL ENGINEERS, SINCE 1919

